

歐品電子(昆山)有限公司

OUPIIN ELECTRONIC(KUNSHAN) CO.,LTD.

PACKAGING SPECIFICATION (包裝作業規範)

CONFIDENTIAL TOP SECRET

SPEC.NO.(規範編號)	Q2043SPP-169			PAGE	1/6	REV.	E
APPLICABLE CUSTOMER (適用客戶)	ALL	APPLICABLE PRODUCT (適用產品)	2043-1XxxGxxSA	PACKAGING CATEGORY (包裝方式)	TRAY PLATE PACKING		

REVISION HISTORY (修訂履歷)

REV.	ECN NO	PAGE (頁次)							
		1	2	3	4				
C		Change SPP as standard. (改為標準SPP.)							
D		Correct the materials. (修正資料.)							
E		Revising one holds quantity . (修改盤裝數量.)							

DIVISION (事業單位)	Product Development (產品開發課)	APPROVED (核准)	CHECKED (審核)	PREPARED (制表)	GW 09/25'15
-----------------	-----------------------------	---------------	--------------	---------------	-------------

歐品電子(昆山)有限公司

OUIPIN ELECTRONIC(KUNSHAN) CO.,LTD.

PACKAGING SPECIFICATION (包裝作業規範)

■ CONFIDENTIAL □ TOP SECRET

SPEC.NO.(規範編號) Q2043SPP-169

PAGE 2/6 REV. E

PACKING OPERATION DIAGRAM & INSTRUCTION (包裝作業圖示及說明)

REMARK (備注)

Laying Product Diagram:
(產品擺放圖示)

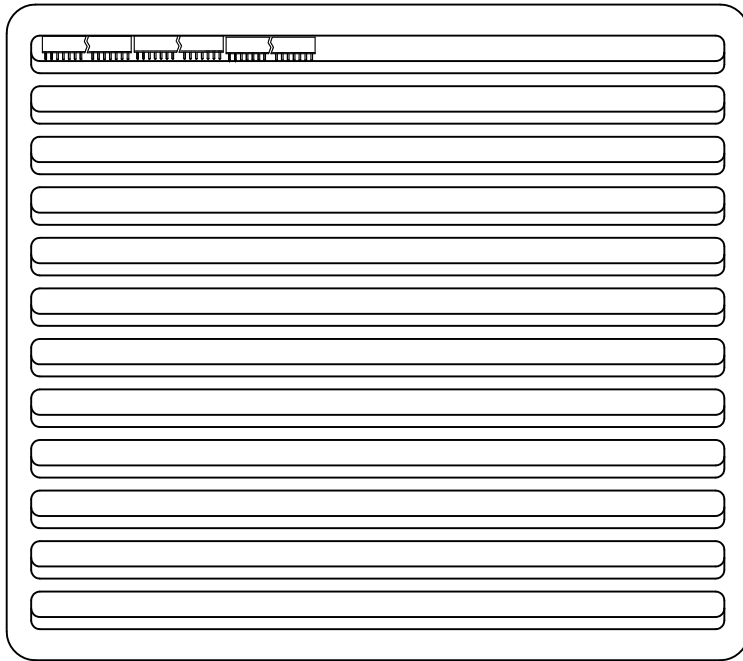

一.PVC Plate Packing Mode:
(PVC盤包裝方式)

- (1).CT-0.9 Box: PVC-2045-01 XX PCS.
(CT-0.9 規格的紙箱放PVC-2045-01盤 XX PCS)
- (2).Put product in each trough fully as shown in diagram.
(產品在盤子中擺放方式如圖所示)
- (3).After filling each trough with product fully,cover it with transparent upper cover PVC-2045-01 1PCS。
(每盤放滿產品後,加蓋透明上蓋 PVC-2045-01 1PCS)
- (4).Stack the XX PVC plates filled with product, put them in the paper box in which has been put waterproof bag.
(將放滿產品的XX個PVC盤疊起,裝入防水袋放入紙箱內)

歐品電子(昆山)有限公司

OUIPIN ELECTRONIC(KUNSHAN) CO.,LTD.

PACKAGING SPECIFICATION (包裝作業規範)

<input checked="" type="checkbox"/> CONFIDENTIAL	<input type="checkbox"/> TOP SECRET		
PAGE	3/6	REV.	E

SPEC.NO.(規範編號) Q2043SPP-169

PACKING OPERATION DIAGRAM & INSTRUCTION (包裝作業圖示及說明)

REMARK (備注)

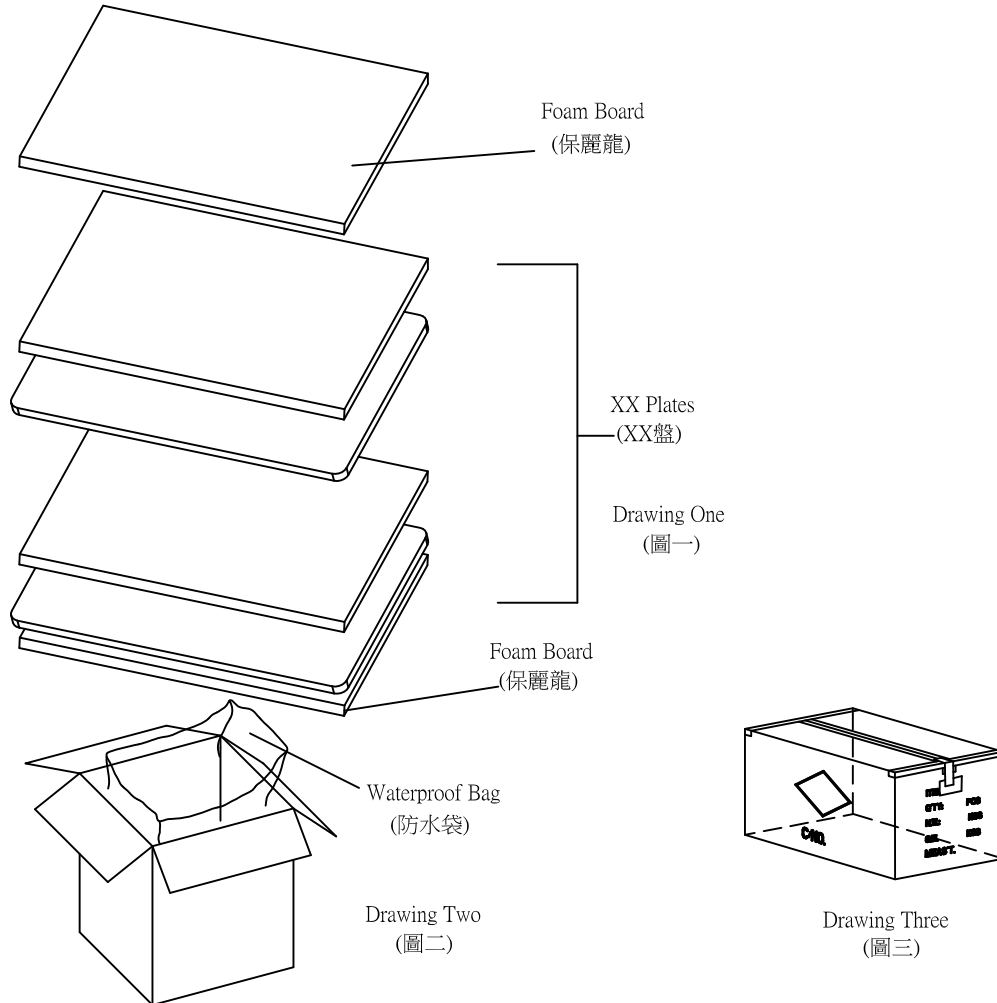

一. Outer Box Packing Mode:

(外箱包裝方式)

- (1). Paper box 0.9 standard 1 PCS, as shown in drawing Two.
(紙箱 0.9 規格 1 PCS, 如(圖二)所示)
- (2). Put one Foam Board in the upper and lower of the paper box, 2PCS in all, as shown in drawing One.
(每箱上下各放一塊保麗龍, 共 2PCS, 如(圖一)所示)
- (3). Put 1 PCS waterproof in the paper box, as shown in drawing Two.
(紙箱內側放入防水袋 1 PCS, 如(圖二)所示)
- (4). Piled the XX packing plates packed up in the waterproof.
(將放滿產品的 XX 個 PVC 盤疊起, 裝入防水袋內)
- (5). Seal the waterproof bag, then put the Foam Board 1PCS on the bag.
(Put 1 PCS Foam Board at the right and left side in the paper box if it is necessary.)
(封上防水袋, 然後放上第二塊保麗龍薄板)
(必要時, 在紙箱的左右兩側各放一塊保麗龍)
- (6). Seal the surface of the outer box, as shown in drawing Three.
(將外箱上層封口, 如(圖三)所示)

The form on the right and flank side of the box must be filled correctly and clearly, take actual testing weight as the standard of each box gross weight.

外箱之正麥和側麥所要填寫之項目要填寫正確, 清晰, 每箱之毛重應以實測重量為準。

歐品電子(昆山)有限公司

OUPIIN ELECTRONIC(KUNSHAN) CO.,LTD.

PACKAGING SPECIFICATION (包裝作業規範)

CONFIDENTIAL TOP SECRET

SPEC.NO.(規範編號)		Q2043SPP-169										PAGE:	4/6	REV.	E
PACKING MATERIAL (包裝材料)			PRODUCT P/N	CT NO.	PACKING N.W.	PACKING QUANTITY (包裝數量)			WEIGHT (重量) kg						
MATERIAL NAME (材料名稱)	PART NO. (料號)	QTY	(產品料號)	(紙箱規格)	(包材重量)	PCS/TRAY	TRAY/BOX	PCS/BOX	N.W./PCS	N.W./BOX	G.W./BOX				
PAPER BOXES (紙箱)	CT-0.9	1	2043-1X02GxxSA	CT-0.9	4.78	540	60	33840	0.000152	5.14	9.93				
Packing Box (包裝盒)	PVC-2045-01	----	2043-1X03GxxSA	CT-0.9	4.78	360	60	21600	0.000228	4.92	9.71				
			2043-1X04GxxSA	CT-0.9	4.78	264	60	15840	0.000304	4.82	9.60				
			2043-1X05GxxSA	CT-0.9	4.78	216	60	12960	0.00038	4.92	9.71				
Packing Box Cover (包裝盒蓋子)	PVC-2045-01	----	2043-1X06GxxSA	CT-0.9	4.78	180	60	10800	0.000456	4.92	9.71				
			2043-1X07GxxSA	CT-0.9	4.78	156	60	9360	0.000532	4.98	9.76				
			2043-1X08GxxSA	CT-0.9	4.78	132	60	7920	0.000608	4.82	9.60				
WATERPROOF BAG (防水袋)	100*70	1	2043-1X09GxxSA	CT-0.9	4.78	120	60	7200	0.000684	4.92	9.71				
			2043-1X10GxxSA	CT-0.9	4.78	108	60	6480	0.00076	4.92	9.71				
			2043-1X11GxxSA	CT-0.9	4.78	96	60	5760	0.000836	4.82	9.60				
Foam (保麗龍)	-----	2	2043-1X12GxxSA	CT-0.9	4.78	84	60	5040	0.000912	4.60	9.38				
			2043-1X13GxxSA	CT-0.9	4.78	84	60	5040	0.000988	4.98	9.76				
			2043-1X14GxxSA	CT-0.9	4.78	72	60	4320	0.001064	4.60	9.38				
DRYING AGENT (干燥劑)	-----	3	2043-1X15GxxSA	CT-0.9	4.78	72	60	4320	0.00114	4.92	9.71				
			2043-1X16GxxSA	CT-0.9	4.78	60	60	3600	0.001216	4.38	9.16				
			2043-1X17GxxSA	CT-0.9	4.78	60	60	3600	0.001292	4.65	9.43				
			2043-1X18GxxSA	CT-0.9	4.78	60	60	3600	0.001368	4.92	9.71				
			2043-1X19GxxSA	CT-0.9	4.78	48	60	2880	0.001444	4.16	8.94				

1.NOTE:

(注意)

When the finished products have been made,take the actual weight as the standard of gross weight in each box.

(成品出貨時,每箱之毛重應以實測重量為準)

When the finished products have been made,stick the proper designation list on the box according to product demand.

(成品出貨時,依據出貨要求貼上相對應的標籤單)

歐品電子(昆山)有限公司

OUPIIN ELECTRONIC(KUNSHAN) CO.,LTD.

PACKAGING SPECIFICATION (包裝作業規範)

CONFIDENTIAL TOP SECRET

SPEC.NO.(規範編號) Q2043SPP-169 PAGE: 5/6 REV. E

PACKING MATERIAL (包裝材料)			PRODUCT P/N	CT NO.	PACKING N.W.	PACKING QUANTITY (包裝數量)			WEIGHT (重量) kg		
MATERIAL NAME (材料名稱)	PART NO. (料號)	Q'TY	(產品料號)	(紙箱規格)	(包材重量)	PCS/TRAY	TRAY/BOX	PCS/BOX	N.W./PCS	N.W./BOX	G.W./BOX
PAPER BOXES (紙箱)	CT-0.9	1	2043-1X20GxxSA	CT-0.9	4.78	48	60	2880	0.00152	4.38	9.16
Packing Box (包裝盒)	PVC-2045-01	----	2043-1X21GxxSA	CT-0.9	4.78	48	60	2880	0.001596	4.60	9.38
			2043-1X22GxxSA	CT-0.9	4.78	48	60	2880	0.001672	4.82	9.60
			2043-1X23GxxSA	CT-0.9	4.78	48	60	2880	0.001748	5.03	9.82
			2043-1X24GxxSA	CT-0.9	4.78	36	60	2160	0.001824	3.94	8.72
Packing Box Cover (包裝盒蓋子)	PVC-2045-01	----	2043-1X25GxxSA	CT-0.9	4.78	36	60	2160	0.0019	4.10	8.89
			2043-1X26GxxSA	CT-0.9	4.78	36	60	2160	0.001976	4.27	9.05
			2043-1X27GxxSA	CT-0.9	4.78	36	60	2160	0.002052	4.43	9.22
WATERPROOF BAG (防水袋)	100*70	1	2043-1X28GxxSA	CT-0.9	4.78	36	60	2160	0.002128	4.60	9.38
			2043-1X29GxxSA	CT-0.9	4.78	36	60	2160	0.002204	4.76	9.54
			2043-1X30GxxSA	CT-0.9	4.78	36	60	2160	0.00228	4.92	9.71
Foam (保麗龍)	-----	2	2043-1X31GxxSA	CT-0.9	4.78	36	60	2160	0.002356	5.09	9.87
			2043-1X32GxxSA	CT-0.9	4.78	24	60	1440	0.002432	3.50	8.29
			2043-1X33GxxSA	CT-0.9	4.78	24	60	1440	0.002508	3.61	8.39
DRYING AGENT (干燥劑)	-----	3	2043-1X34GxxSA	CT-0.9	4.78	24	60	1440	0.002584	3.72	8.50
			2043-1X35GxxSA	CT-0.9	4.78	24	60	1440	0.00266	3.83	8.61
			2043-1X36GxxSA	CT-0.9	4.78	24	60	1440	0.002736	3.94	8.72
			2043-1X37GxxSA	CT-0.9	D	24	60	1440	0.002812	4.05	#VALUE!

1.NOTE:
 (注意)
 When the finished products have been made,take the actual weight as the standard of gross weight in each box.
 (成品出貨時,每箱之毛重應以實測重量為準)
 When the finished products have been made,stick the proper designation list on the box according to product demand.
 (成品出貨時,依據出貨要求貼上相對應的標籤單)

歐品電子(昆山)有限公司

OUPIIN ELECTRONIC(KUNSHAN) CO.,LTD.

PACKAGING SPECIFICATION (包裝作業規範)

CONFIDENTIAL TOP SECRET

SPEC.NO.(規範編號)		Q2043SPP-169										PAGE:	6/6	REV.	E
PACKING MATERIAL (包裝材料)			PRODUCT P/N	CT NO.	PACKING N.W.	PACKING QUANTITY (包裝數量)			WEIGHT (重量) kg						
MATERIAL NAME (材料名稱)	PART NO. (料號)	Q'TY	(產品料號)	(紙箱規格)	(包材重量)	PCS/TRAY	TRAY/BOX	PCS/BOX	N.W./PCS	N.W./BOX	G.W./BOX				
PAPER BOXES (紙箱)	CT-0.9	1	2043-1X38GxxSA	CT-0.9	4.78	24	60	1440	0.002888	4.16	8.94				
Packing Box (包裝盒)	PVC-2045-01	----	2043-1X39GxxSA	CT-0.9	4.78	24	60	1440	0.002964	4.27	9.05				
			2043-1X40GxxSA	CT-0.9	4.78	24	60	1440	0.00304	4.38	9.16				
Packing Box Cover (包裝盒蓋子)	PVC-2045-01	----													
WATERPROOF BAG (防水袋)	100*70	1													
Foam (保麗龍)	-----	2													
DRYING AGENT (干燥劑)	-----	3													

1.NOTE:
(注意)
When the finished products have been made,take the actual weight as the standard of gross weight in each box.
(成品出貨時,每箱之毛重應以實測重量為準)
When the finished products have been made,stick the proper designation list on the box according to product demand.
(成品出貨時,依據出貨要求貼上相對應的標籤單)