

歐品電子(昆山)有限公司

OUPIN ELECTRONIC(KUNSHAN) CO.,LTD.

PACKAGING SPECIFICATION (包裝作業規範)

CONFIDENTIAL TOP SECRET

SPEC.NO.(規範編號) Q2044SPP-122				PAGE	1/6	REV.	K
APPLICABLE CUSTOMER (適用客戶)	ALL	APPLICABLE PRODUCT (適用產品)	2044-2XxxG(T)xxS(P)A 2044-2XxxG(T)xxS(P)A/6T 2044-2XxxGxxSA-LCP 2044-2XxxG(T)xxS(P)A-HT 2044-2XxxG(T)xxS(P)A-xxxx		PACKAGING CATEGORY (包裝方式)	TRAY PLATE PACKING	

REVISION HISTORY (修訂履歷)

REV.	ECN NO	PAGE (頁次)								
		1	2	3	4	5	6			
H		Add control mark of Air Column Bag thickness T=10mm (新增气柱袋厚度管控標示T=10mm)								
J		Add item number (新增料号)								
K		Add item number (新增料号)								

DIVISION (事業單位)	Product Development (產品開發課)	APPROVED (核准)		CHECKED (審核)		PREPARED (制表)	ZY 05/29'22
-----------------	-----------------------------	---------------	--	--------------	--	---------------	-------------

歐品電子(昆山)有限公司

OUPIIN ELECTRONIC(KUNSHAN) CO.,LTD.

PACKAGING SPECIFICATION (包裝作業規範)

CONFIDENTIAL TOP SECRET

SPEC.NO.(規範編號) Q2044SPP-122

PAGE 2/6 REV. K

PACKING OPERATION DIAGRAM & INSTRUCTION (包裝作業圖示及說明)

REMARK (備注)

Laying Product Diagram:
(產品擺放圖示)

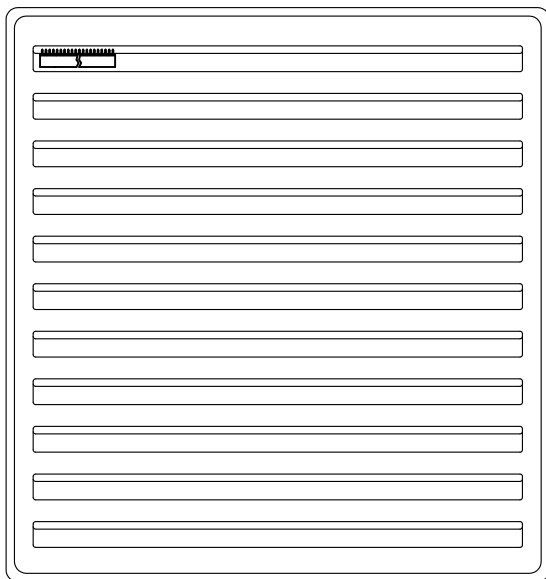

- 一.PVC Plate Packing Mode:
(PVC盤包裝方式)
- (1).CT-0.9 Box: PVC-2045-02.
(CT-0.9 規格的紙箱放PVC-2045-02盤)
 - (2).Put product in each trough fully as shown in diagram.
(產品在盤子中擺放方式如圖所示)
 - (3).After filling each trough with product fully,cover it with transparent upper cover PVC-2045-02 1PCS 。
(每盤放滿產品後,加蓋透明上蓋 PVC-2045-02 1PCS)
 - (4).Stack the XX PVC plates filled with product, put them in the paper box in which has been put waterproof bag.
(將放滿產品的XX個PVC盤疊起,裝入防水袋放入紙箱內)

歐品電子(昆山)有限公司

OUPIIN ELECTRONIC(KUNSHAN) CO.,LTD.

PACKAGING SPECIFICATION (包裝作業規範)

<input checked="" type="checkbox"/> CONFIDENTIAL		<input type="checkbox"/> TOP SECRET	
PAGE	3/6	REV.	K

SPEC.NO.(規範編號) Q2044SPP-122

PACKING OPERATION DIAGRAM & INSTRUCTION (包裝作業圖示及說明)

REMARK (備注)

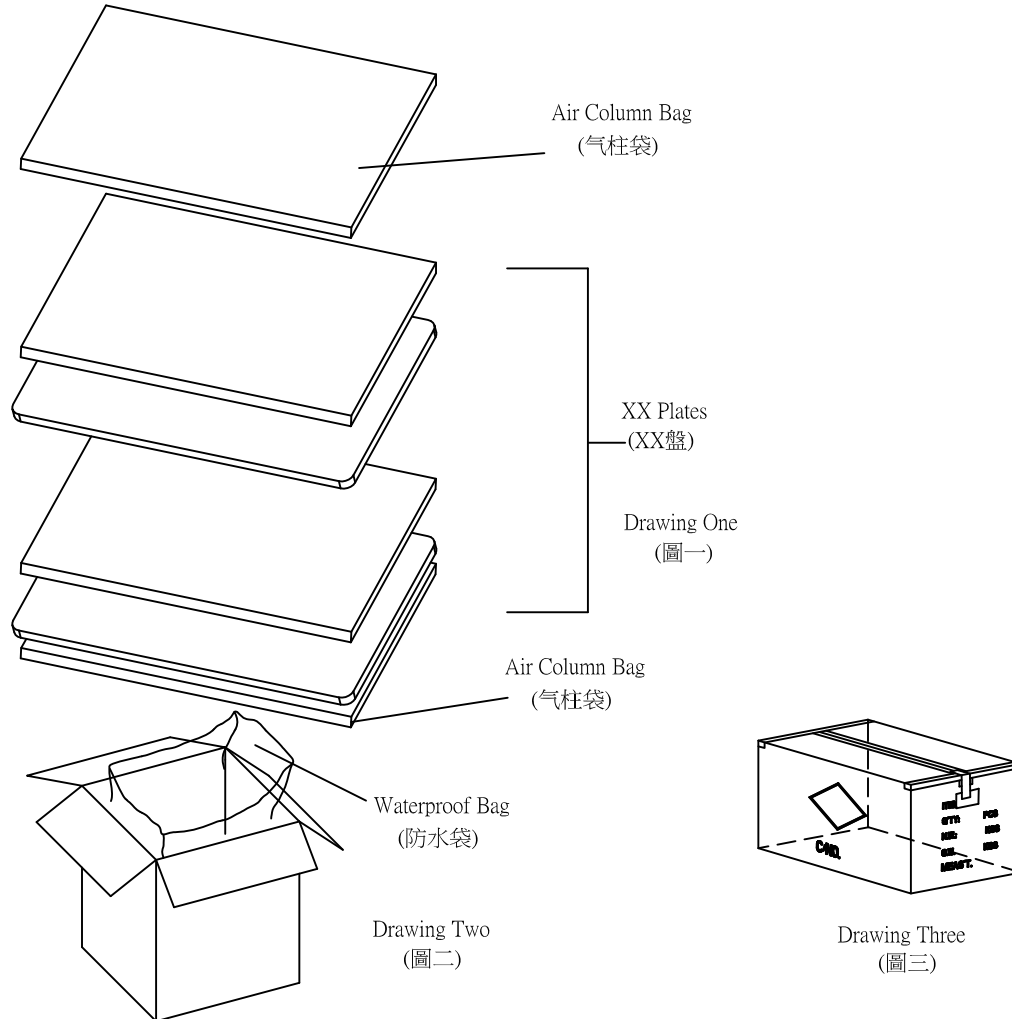

一. Outer Box Packing Mode:

(外箱包裝方式)

- (1). Paper box 0.9 standard 1 PCS, as shown in drawing Two.
(紙箱 0.9 規格 1 PCS, 如(圖二)所示)
- (2). Put one Air Column Bag in the upper and lower of the paper box, 2PCS in all, as shown in drawing One.
(每箱上下各放一塊气柱袋, 共 2PCS, 如(圖一)所示)
- (3). Put 1 PCS waterproof in the paper box, as shown in drawing Two.
(紙箱內側放入防水袋 1 PCS, 如(圖二)所示)
- (4). Piled the XX packing plates packed up in the waterproof.
(將放滿產品的 XX 個 PVC 盤疊起, 裝入防水袋內)
- (5). Seal the waterproof bag, then put the Air Column Bag 1PCS on the bag.
(Put 1 PCS Air Column Bag at the right and left side in the paper box if it is necessary.)
(封上防水袋, 然後放上第二塊气柱袋薄板)
(必要時, 在紙箱的左右兩側各放一塊气柱袋)
- (6). Seal the surface of the outer box, as shown in drawing Three.
(將外箱上層封口, 如(圖三)所示)

The form on the right and flank side of the box must be filled correctly and clearly, take actual testing weight as the standard of each box gross weight.

外箱之正麥和側麥所要填寫之項目要填寫正確, 清晰, 每箱之毛重應以實測重量為準。

歐品電子(昆山)有限公司

OUPIIN ELECTRONIC(KUNSHAN) CO.,LTD.

PACKAGING SPECIFICATION (包裝作業規範)

CONFIDENTIAL TOP SECRET

SPEC.NO.(規範編號)		Q2044SPP-122										PAGE:	4/6	REV.	K
PACKING MATERIAL (包裝材料)			PRODUCT P/N		CT NO.	PACKING N.W.	PACKING QUANTITY (包裝數量)			WEIGHT (重量) kg					
MATERIAL NAME (材料名稱)	PART NO. (料號)	Q'TY	(產品料號)	(紙箱規格)	(包材重量)	PCS/TRAY	TRAY/BOX	PCS/BOX	N.W./PCS	N.W./BOX	G.W./BOX				
PAPER BOXES (紙箱)	CT-0.9	1	2044-2X02GxxSA/6T/HT-LCP	CT-0.9	2.69	473	40	18920	0.00036	6.81	9.50				
Packing Box (包裝盒)	PVC-2045-02		2044-2X03GxxSA/6T/HT-LCP	CT-0.9	2.69	319	40	12760	0.00054	6.89	9.58				
			2044-2X04GxxSA/6T/HT-LCP	CT-0.9	2.69	242	40	9680	0.00072	6.97	9.66				
Packing Box Cover (包裝盒蓋子)	PVC-2045-02	----	2044-2X05GxxSA/6T/HT-LCP	CT-0.9	2.69	198	40	7920	0.00090	7.13	9.82				
			2044-2X06GxxSA/6T/HT-LCP	CT-0.9	2.69	165	40	6600	0.00108	7.13	9.82				
			2044-2X07GxxSA/6T/HT-LCP	CT-0.9	2.69	143	40	5720	0.00126	7.21	9.90				
WATERPROOF BAG (防水袋)	PE 100*70	1	2044-2X08GxxSA/6T/HT-LCP	CT-0.9	2.69	121	40	4840	0.00144	6.97	9.66				
			2044-2X09GxxSA/6T/HT-LCP	CT-0.9	2.69	110	40	4400	0.00162	7.13	9.82				
			2044-2X10GxxSA/6T/HT-LCP	CT-0.9	2.69	99	40	3960	0.00180	7.13	9.82				
Air Column Bag (氣柱袋)	厚度T=10mm	2	2044-2X11GxxSA/6T/HT-LCP	CT-0.9	2.69	88	40	3520	0.00198	6.97	9.66				
			2044-2X12GxxSA/6T/HT-LCP	CT-0.9	2.69	77	40	3080	0.00216	6.65	9.34				
			2044-2X13GxxSA/6T/HT-LCP	CT-0.9	2.69	77	40	3080	0.00234	7.21	9.90				
DRYING AGENT (干燥劑)	-----	3	2044-2X14GxxSA/6T/HT-LCP	CT-0.9	2.69	56	40	2640	0.00252	6.65	9.34				
			2044-2X15GxxSA/6T/HT-LCP	CT-0.9	2.69	56	40	2640	0.00270	7.13	9.82				
			2044-2X16GxxSA/6T/HT-LCP	CT-0.9	2.69	55	40	2200	0.00288	6.34	9.03				
			2044-2X17GxxSA/6T/HT-LCP	CT-0.9	2.69	55	40	2200	0.00306	6.73	9.42				
			2044-2X18GxxSA/6T/HT-LCP	CT-0.9	2.69	55	40	2200	0.00324	7.13	9.82				

1.NOTE:

(注意)

When the finished products have been made,take the actual weight as the standard of gross weight in each box.

(成品出貨時,每箱之毛重應以實測重量為準)

When the finished products have been made,stick the proper designation list on the box according to product demand.

(成品出貨時,依據出貨要求貼上相對應的標籤單)

歐品電子(昆山)有限公司

OUPIIN ELECTRONIC(KUNSHAN) CO.,LTD.

PACKAGING SPECIFICATION (包裝作業規範)

CONFIDENTIAL TOP SECRET

SPEC.NO.(規範編號)		Q2044SPP-122						PAGE:		5/6	REV.	K
PACKING MATERIAL (包裝材料)			PRODUCT P/N		CT NO.	PACKING N.W.	PACKING QUANTITY (包裝數量)			WEIGHT (重量) kg		
MATERIAL NAME (材料名稱)	PART NO. (料號)	Q'TY	(產品料號)		(紙箱規格)	(包材重量)	PCS/TRAY	TRAY/BOX	PCS/BOX	N.W./PCS	N.W./BOX	G.W./BOX
PAPER BOXES (紙箱)	CT-0.9	1	2044-2X19GxxSA/6T/HT-LCP		CT-0.9	2.69	44	40	1760	0.00342	6.02	8.71
Packing Box (包裝盒)	PVC-2045-02		2044-2X20GxxSA/6T/HT-LCP		CT-0.9	2.69	44	40	1760	0.00360	6.34	9.03
			2044-2X21GxxSA/6T/HT-LCP		CT-0.9	2.69	44	40	1760	0.00378	6.65	9.34
Packing Box Cover (包裝盒蓋子)	PVC-2045-02	----	2044-2X22GxxSA/6T/HT-LCP		CT-0.9	2.69	44	40	1760	0.00396	6.97	9.66
			2044-2X23GxxSA/6T/HT-LCP		CT-0.9	2.69	44	40	1760	0.00414	7.29	9.98
			2044-2X24GxxSA/6T/HT-LCP		CT-0.9	2.69	33	40	1320	0.00432	5.70	8.39
WATERPROOF BAG (防水袋)	PE 100*70	1	2044-2X25GxxSA/6T/HT-LCP		CT-0.9	2.69	33	40	1320	0.00450	5.94	8.63
			2044-2X26GxxSA/6T/HT-LCP		CT-0.9	2.69	33	40	1320	0.00468	6.18	8.87
			2044-2X27GxxSA/6T/HT-LCP		CT-0.9	2.69	33	40	1320	0.00486	6.42	9.11
Air Column Bag (气柱袋)	厚度T = 10mm	2	2044-2X28GxxSA/6T/HT-LCP		CT-0.9	2.69	33	40	1320	0.00504	6.65	9.34
			2044-2X29GxxSA/6T/HT-LCP		CT-0.9	2.69	33	40	1320	0.00522	6.89	9.58
			2044-2X30GxxSA/6T/HT-LCP		CT-0.9	2.69	33	40	1320	0.00540	7.13	9.82
DRYING AGENT (干燥劑)	-----	3	2044-2X31GxxSA/6T/HT-LCP		CT-0.9	2.69	22	40	880	0.00558	4.91	7.60
			2044-2X32GxxSA/6T/HT-LCP		CT-0.9	2.69	22	40	880	0.00576	5.07	7.76
			2044-2X33GxxSA/6T/HT-LCP		CT-0.9	2.69	22	40	880	0.00594	5.23	7.92
			2044-2X34GxxSA/6T/HT-LCP		CT-0.9	2.69	22	40	880	0.00612	5.39	8.08
			2044-2X35GxxSA/6T/HT-LCP		CT-0.9	2.69	22	40	880	0.00630	5.54	8.23

1.NOTE:

(注意)

When the finished products have been made,take the actual weight as the standard of gross weight in each box.

(成品出貨時,每箱之毛重應以實測重量為準)

When the finished products have been made,stick the proper designation list on the box according to product demand.

(成品出貨時,依據出貨要求貼上相對應的標籤單)

歐品電子(昆山)有限公司

OUPIIN ELECTRONIC(KUNSHAN) CO.,LTD.

PACKAGING SPECIFICATION (包裝作業規範)

CONFIDENTIAL TOP SECRET

SPEC.NO.(規範編號)		Q2044SPP-122										PAGE:	6/6	REV.	K
PACKING MATERIAL (包裝材料)			PRODUCT P/N	CT NO.	PACKING N.W.	PACKING QUANTITY (包裝數量)			WEIGHT (重量) kg						
MATERIAL NAME (材料名稱)	PART NO. (料號)	Q'TY	(產品料號)	(紙箱規格)	(包材重量)	PCS/TRAY	TRAY/BOX	PCS/BOX	N.W./PCS	N.W./BOX	G.W./BOX				
PAPER BOXES (紙箱)	CT-0.9	1	2044-2X36GxxSA/6T/HT-LCP	CT-0.9	2.69	22	40	880	0.00648	5.70	8.39				
Packing Box (包裝盒)	PVC-2045-02		2044-2X37GxxSA/6T/HT-LCP	CT-0.9	2.69	22	40	880	0.00666	5.86	8.55				
			2044-2X38GxxSA/6T/HT-LCP	CT-0.9	2.69	22	40	880	0.00684	6.02	8.71				
			2044-2X39GxxSA/6T/HT-LCP	CT-0.9	2.69	22	40	880	0.00702	6.18	8.87				
Packing Box Cover (包裝盒蓋子)	PVC-2045-02	----	2044-2X40GxxSA/6T/HT-LCP	CT-0.9	2.69	22	40	880	0.00720	6.34	9.03				
			2044-2x04GxxSA-xxxx	CT-0.9	2.69	242	40	9680	0.00050	4.84	7.53				
WATERPROOF BAG (防水袋)	PE 100*70	1													
Air Column Bag (氣柱袋)	厚度T=10mm	2													
DRYING AGENT (干燥劑)	-----	3													

1.NOTE:

(注意)

When the finished products have been made,take the actual weight as the standard of gross weight in each box.

(成品出貨時,每箱之毛重應以實測重量為準)

When the finished products have been made,stick the proper designation list on the box according to product demand.

(成品出貨時,依據出貨要求貼上相對應的標籤單)