

歐品電子(昆山)有限公司

OUPIIN ELECTRONIC(KUNSHAN) CO.,LTD.

PACKAGING SPECIFICATION (包裝作業規範)

CONFIDENTIAL TOP SECRET

SPEC.NO.(規範編號) Q2044SPP-541				PAGE	1/4	REV.	D	
APPLICABLE CUSTOMER (適用客戶)	ALL	APPLICABLE PRODUCT (適用產品)	2044-1XxxGxxS(P)B(-Axxx)				PACKAGING CATEGORY (包裝方式)	PVC-BOX PACKING

REVISION HISTORY (修訂履歷)

REV.	ECN NO	PAGE (頁次)							
		1	2	3	4				
A		New Version (新版發行)							
B		Add P/N 新增料號							
C		Add (P) P/N 增加(P)料號							
D		Add New P/N 增加新料號							

DIVISION (事業單位)	Product Development (產品開發課)	APPROVED (核准)		CHECKED (審核)		PREPARED (制表)	11/09'19
-----------------	-----------------------------	---------------	--	--------------	--	---------------	----------

歐品電子(昆山)有限公司

OUPIIN ELECTRONIC(KUNSHAN) CO.,LTD.

PACKAGING SPECIFICATION (包裝作業規範)

<input checked="" type="checkbox"/> CONFIDENTIAL	<input type="checkbox"/> TOP SECRET		
PAGE	2/4	REV.	D

SPEC.NO.(規範編號) Q2044SPP-541

PACKING OPERATION DIAGRAM & INSTRUCTION (包裝作業圖示及說明)

REMARK (備注)

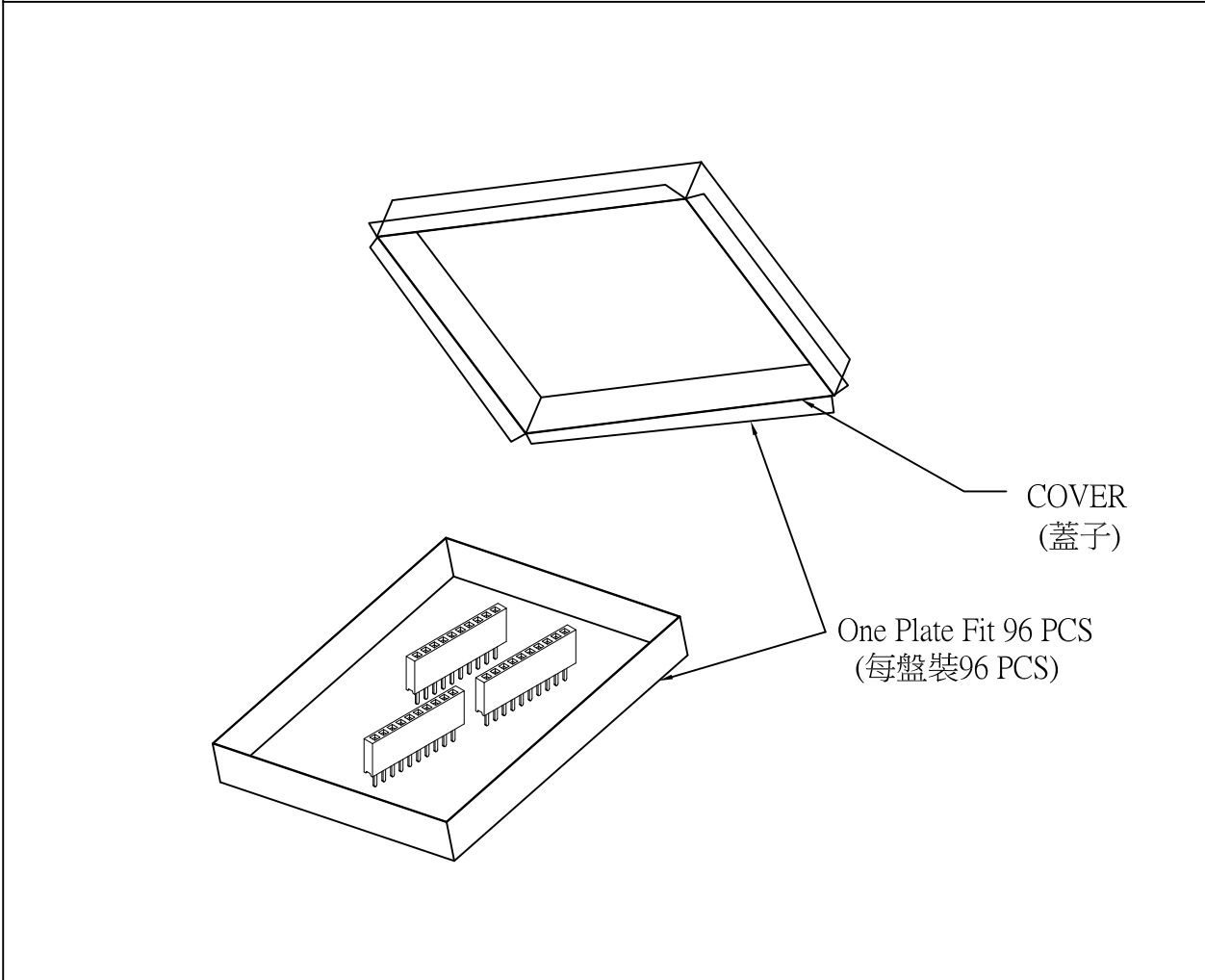

- 一.PVC Plate Packing Mode:
(PVC盤包裝方式)
- (1).PVC-214
- (2).Every box should have upper and lower cover.
(每個PVC盒有上蓋和下蓋)
- (3).Put Product 96PCS in each box.
(每個盒中放96PCS產品)
- (4).Install Product:Put the finished product in the case neatly.
(產品放置方式:將成品擺放整齊放置於盒中)
- (5).After instal IXX PCS product, cover the packing box,
seal the cover with sticky belt.
(放滿XXPCS產品後,在包裝盒上下蓋起,
用膠帶封住蓋子)
- (6).Put the PVC box filled with product in the paper box
in which the waterproof bag has been laid.
(將放滿產品的PVC盒裝入放好防水袋的紙箱內)

歐品電子(昆山)有限公司

OUPIIN ELECTRONIC(KUNSHAN) CO.,LTD.

PACKAGING SPECIFICATION (包裝作業規範)

<input checked="" type="checkbox"/> CONFIDENTIAL <input type="checkbox"/> TOP SECRET	
PAGE	3/4
REV.	D

SPEC.NO.(規範編號) Q2044SPP-541

PACKING OPERATION DIAGRAM & INSTRUCTION (包裝作業圖示及說明)	REMARK (備注)
<p>(Drawing One) (圖一) 480mm(L)*290(W)*240MM(H)</p> <p>(Drawing Two) (圖二) 12 Layers (12層)</p> <p>(Drawing Three) (圖三)</p> <p>(Drawing Four) (圖四) Paper Box Allocating Foam (紙箱配套泡沫)</p> <p>(Drawing Five) (圖五)</p>	<p>二。Outer Box Packing Mode: (外箱包裝方式)</p> <ol style="list-style-type: none"> (1).Paper Box(CT-0.9)1PCS(Drawing One). 紙箱(CT-0.9)1PCS(圖一). (2).Put 1PCS alocating foam at the bottom of the paper box, put 1PCS waterproof bag on the foam(Drawing One). 底層放入紙箱配套泡沫1PCS.上面放入防水袋1PCS(圖一). (3).Seal the waterproof after folding 12layers PVC box(Drawing Two). 疊好12層PVC盒後封上防水袋(圖二). (4).Put 1PCS allocating form at each side in the paper box(Drawing Three). 紙箱裡面四側放入配套泡沫各1PCS(圖三). (5).Put 1PCS allocating foam at the uppermost layer of the paper box (Drawing Four). 最上層放入紙箱配套泡沫1PCS(圖四). (6).Seal the surface of the outer box(Drawing Five). 將外箱上層封口(圖五). <p>The form on the right and flank side of the box must be filled correctly and clearly,take actual testing weight as the standard of each box groos weight. (外箱之正面和側面所要填寫之項目要填寫正確,清晰,每箱之毛重應以實測重量為準)</p>

