

歐品電子(昆山)有限公司

OUPIIN ELECTRONIC(KUNSHAN) CO.,LTD.

PACKAGING SPECIFICATION (包裝作業規範)

CONFIDENTIAL TOP SECRET

SPEC.NO.(規範編號) Q2042SPP-602		PAGE 1/5		REV. J	
APPLICABLE CUSTOMER (適用客戶)	ALL	APPLICABLE PRODUCT (適用產品)	2042-1XxxGxxX(P)B 2042-1XxxGxxSB/HT 2042-1XxxGxxSB/Axxx	PACKAGING CATEGORY (包裝方式)	PVC-BOX PACKING
			2042-1XxxTSB 2042-2XxxGxxX(P)B 2042-2XxxGxxSB/HT		

REVISION HISTORY (修訂履歷)

ECN REV. NO	PAGE (頁次)								
	1	2	3	4	5				
D	Newly-increased material number 新增料號								
E	The inner box increases labels 內盒增加標籤								
F	Modify the packing quantity 修改包裝數量								
G	Modify the packing quantity 修改包裝數量								
H	Modify the packing weight 修改包裝重量								
J	Modify the packing weight 修改包裝重量								

DIVISION (事業單位)	Product Development (產品開發課)	APPROVED (核准)		CHECKED (審核)		PREPARED (制表)	CCH 07/15'22
-----------------	-----------------------------	---------------	--	--------------	--	---------------	--------------

歐品電子(昆山)有限公司

OUPIIN ELECTRONIC(KUNSHAN) CO.,LTD.

PACKAGING SPECIFICATION (包裝作業規範)

<input checked="" type="checkbox"/> CONFIDENTIAL	<input type="checkbox"/> TOP SECRET		
PAGE	2/5	REV.	J

SPEC.NO.(規範編號) Q2042SPP-602

PACKING OPERATION DIAGRAM & INSTRUCTION (包裝作業圖示及說明)

REMARK (備注)

Amphenol
P/N: xxxxxx-xxxx
Q'TY: xxx PCS
Date: xx xx
RoHS Compliant

(Drawing Six)
(圖六)

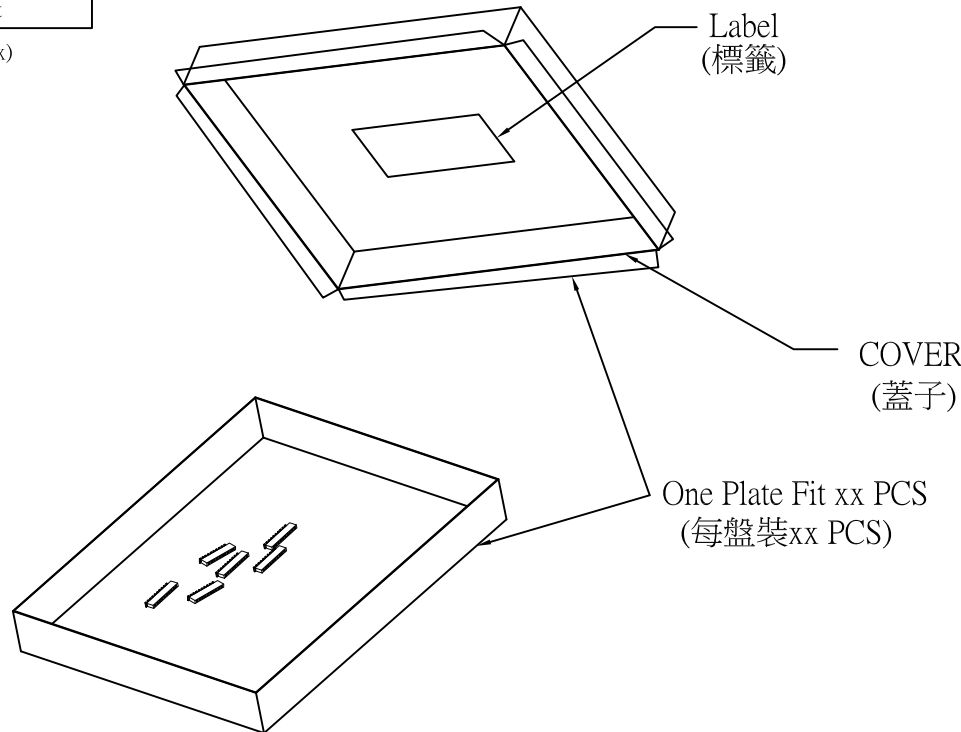

一.PVC Plate Packing Mode:

(PVC盤包裝方式)

(1).PVC-214

(2).Every box should have upper and lower cover.
(每個PVC盒有上蓋和下蓋)

(3).Put Product xx PCS in each box.
(每個盒中放xxPCS產品)

(4).Install Product:Put the finished product in the case neatly.
(產品放置方式:將成品擺放整齊放置於盒中)

(5).After instal lxx PCS product, cover the packing box,
seal the cover with sticky belt.
(放滿xxPCS產品後,在包裝盒上下蓋起,
用膠帶封住蓋子)

(6)2042-1X05G00RPB needs to stick to the little label at the
inner box ' Such as Fig. six)
(2042-1X05G00RPB在內盒上需貼小標籤(如圖六))

(7).Put the PVC box filled with product in the paper box
in which the waterproof bag has been laid.
(將放滿產品的PVC盒裝入放好防水袋的紙箱內)

歐品電子(昆山)有限公司

OUPIIN ELECTRONIC(KUNSHAN) CO.,LTD.

PACKAGING SPECIFICATION (包裝作業規範)

<input checked="" type="checkbox"/> CONFIDENTIAL		<input type="checkbox"/> TOP SECRET	
PAGE	3/5	REV.	J

SPEC.NO.(規範編號) Q2042SPP-602

PACKING OPERATION DIAGRAM & INSTRUCTION (包裝作業圖示及說明)

REMARK (備注)

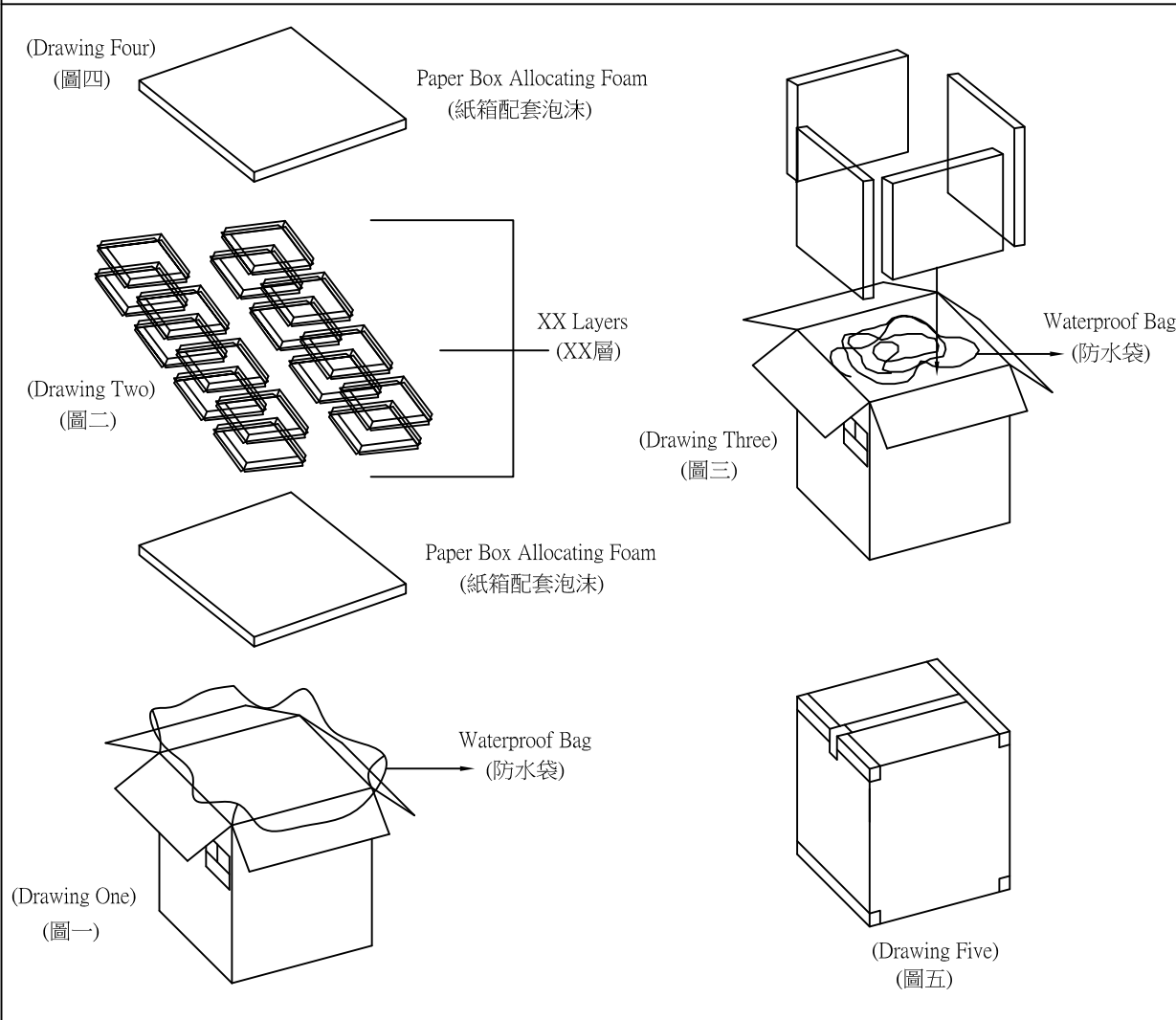

二。Outer Box Packing Mode: (外箱包裝方式)

- (1).Paper Box(CT-0.9)1PCS(Drawing One).
紙箱(CT-0.9)1PCS(圖一).
- (2).Put 1PCS alocating foam at the bottom of the paper box, put 1PCS waterproof bag on the foam(Drawing One).
底層放入紙箱配套泡沫1PCS.上面放入防水袋1PCS(圖一).
- (3).Seal the waterproof after folding XX layers PVC box(Drawing Two).
疊好XX層PVC盒後封上防水袋(圖二).
- (4)Put 1PCS allocating form at each side in the paper box(Drawing Three).
紙箱裡面四側放入配套泡沫各1PCS(圖三).
- (5)Put 1PCS allocating foam at the uppermost layer of the paper box (Drawing Four).
最上層放入紙箱配套泡沫1PCS(圖四).
- (6)Seal the surface of the outer box(Drawing Five).
將外箱上層封口(圖五).

The form on the right and flank side of the box must be filled correctly and clearly,take actual testing weight as the standard of each box groos weight.

(外箱之正面和側面所要填寫之項目要填寫正確,清晰,每箱之毛重應以實測重量為準)

OUPIN ELECTRONIC(KUNSHAN) CO.,LTD.
PACKAGING SPECIFICATION (包裝作業規範)

CONFIDENTIAL TOP SECRET

SPEC.NO.(規範編號)		Q2042SPP-602		PAGE:		4/5		REV.		J	
PACKING MATERIAL (包裝材料)			PRODUCT P/N	PACKING N.W.	PACKING QUANTITY (包裝數量)			WEIGHT (重量) kg			
MATERIAL NAME (材料名稱)	PART NO. (料號)	Q'TY	(產品料號)	(包材重量)	PCS/PVC BOX	PVC BOX/BOX	PCS/BOX	N.W./PCS	N.W./BOX	G.W./BOX	
PAPER BOXES (紙箱)	CT-0.9	1	2042-1X02GxxRB	2.94	500	96	48000	0.000123	5.90	8.84	
Packing Box (包裝盒)	PVC-214	96	2042-1X02GxxSB	2.94	500	96	48000	0.000123	5.90	8.84	
			2042-1X02GxxSB/HT	2.94	500	96	48000	0.000123	5.90	8.84	
			2042-1X02GxxSB/Axxx	2.94	500	96	48000	0.000123	5.90	8.84	
WATERPROOF BAG (防水袋)	PE 100*70	1	2042-1X03GxxSB	2.94	400	96	38400	0.000185	7.10	10.04	
			2042-1X03GxxSB/A001	2.94	400	96	38400	0.000163	6.26	9.20	
			2042-1X03TSB	2.94	400	96	38400	0.000193	7.41	10.35	
Foam (保麗龍)	-----	5	2042-1X04GxxRB	2.94	300	96	28800	0.000193	5.56	8.50	
			2042-1X05GxxRB	2.94	200	96	19200	0.000193	3.71	6.65	
			2042-1X04GxxSB	2.94	300	96	28800	0.000203	5.85	8.79	
			2042-1X05GxxSB	2.94	300	96	28800	0.00014	4.03	6.97	
DRYING AGENT (干燥劑)	-----	3	2042-1X05GxxRPB	2.94	200	96	19200	0.00044	8.45	11.39	
			2042-1X06GxxSB	2.94	200	96	19200	0.000355	6.82	9.76	
			2042-1X07GxxSB/Axxx	2.94	200	96	19200	0.00018	3.46	6.40	
			2042-2X02GxxSB	2.94	400	96	38400	0.000234	8.99	11.93	
			2042-2X02GxxRB	2.94	400	96	38400	0.000235	9.02	11.96	
			2042-2X03GxxSB	2.94	200	96	19200	0.000354	6.80	9.74	
			2042-2X04GxxSB	2.94	198	96	19008	0.00028	5.32	8.26	
			2042-2X04GxxSB/HT	2.94	198	96	19008	0.0002	3.80	6.74	
			2042-2X05GxxSB	2.94	200	96	19200	0.00059	11.33	14.27	
			2042-2X06GxxSB	2.94	200	96	19200	0.00059	11.33	14.27	

1.NOTE:

(注意) When the finished products have been made,take the actual weight as the standard of gross weight in each box.

(成品出貨時,每箱之毛重應以實測重量為準)

When the finished products have been made,stick the proper designation list on the box according to product

OUPIIN ELECTRONIC(KUNSHAN) CO.,LTD.

PACKAGING SPECIFICATION (包裝作業規範)

CONFIDENTIAL TOP SECRET

PAGE: 5/5 REV. J

SPEC.NO.(規範編號) Q2042SPP-602

PACKING MATERIAL (包裝材料)			PRODUCT P/N	PACKING N.W.	PACKING QUANTITY (包裝數量)			WEIGHT (重量) kg		
MATERIAL NAME (材料名稱)	PART NO. (料號)	Q'TY	(產品料號)	(包材重量)	PCS/PVC BOX	PVC BOX/BOX	PCS/BOX	N.W./PCS	N.W./BOX	G.W./BOX
PAPER BOXES (紙箱)	CT-0.9	1	2042-2X06GxxRB	2.94	132	96	12672	0.0007	8.87	11.81
Packing Box (包裝盒)	PVC-214	96	2042-2X04GxxRB	2.94	198	96	19008	0.00047	8.93	11.87
			2042-2X04GxxSPB	2.94	198	96	19008	0.00049	9.31	12.25
WATERPROOF BAG (防水袋)	PE 100*70	1								
Foam (保麗龍)	-----	5								
DRYING AGENT (干燥劑)	-----	3								

1.NOTE:
 (注意) When the finished products have been made,take the actual weight as the standard of gross weight in each box.
 (成品出貨時,每箱之毛重應以實測重量為準)
 When the finished products have been made,stick the proper designation list on the box according to product