



PRODUCT SPECIFICATION OF Oupiin

PRODUCT SPECIFICATION

產品規格書

產品名稱 Description	產品料號 Part No.	圖號 Drawing No.
Power Edge Connector	9393-F2P50Nx1AC(CB)xxPA	9393-D0000-043

PRODUCT NAME 產品名稱	DOCUMENT No.: 文件編號	Rev. 版本	OUPIIN
Power Edge Connector	9393spec-F2P50	B	歐品電子
	Approved 核准	Checked 審核	Prepared 制作
	Q.A. Section Chief	Joseph Yen	12.04/2017



PRODUCT SPECIFICATION OF Oupiin

1. SCOPE 適用範圍

This product specification defines the product performance and the test methods to ascertain the performance of the Power Edge Connector, which is designed and manufactured by Oupiin Electronic Co., Ltd. This product specification is applicable but not only for those part numbers which be shown in the cover page.

本產品規格書規定了由歐品電子有限公司設計生產的 Power Edge 型連接器產品的特性及測試方法。本產品規格書適用於但不局限於封面所顯示的產品料號。

2. REFERENCE DOCUMENTS 參考文件

MIL-STD-1344	Test method for electrical connector 電子連接器測試方法
MIL-STD-202	Test method for electrical components 電子零件測試方法
EIA364	Test method for electrical components 電子零件測試方法
JIS C 0051	Test method for electrical components 電子零件測試方法
MIL-G-45204C	Specification for gold plating 鍍金規格
IEC-512-3	IEC standard for current carrying capacity tests IEC電流測試標準
QQ-N-290A	Specification for nickel plating 鍍鎳規格
MIL-P-81728A	Specification for tin/lead plating 鍍錫鉛規格
MIL-T-10727B	Specification for tin plating 鍍錫規格
UL1977	UL standard for safety of attachment plug and receptacle UL安規要求標準

3. FEATURE & DIMENSIONS 特征及尺寸

3.1. PRODUCT DIMENSION 產品尺寸

These connectors shall have the dimensions as shown in drawing.

本產品的相關尺寸參見圖面。

3.2. MALE AND FEMALE PRODUCT 公母產品裝配

3.2.1. Perpendicular to engaging direction 垂直插入方向

the design of the centering and guiding in the mpc of the free and fixed board connector modules shall accept a misalignment of 0.17MM in transverse and 0.12MM in longitudinal axes of the connector
固定板連接器模件的Mpc裡，連接器設計中心線橫向可接受0.17mm和縱向可接受0.12mm的偏差。



PRODUCT SPECIFICATION OF Oupin

allowed misalignment in transverse axes 在橫向方向允許對插偏差量

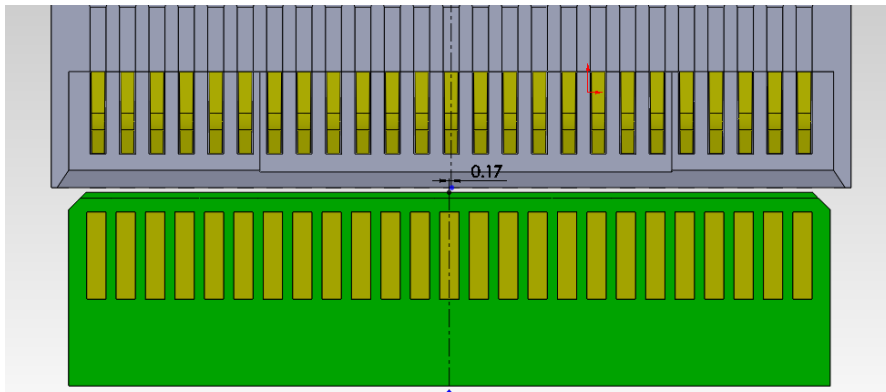

allowed misalignment in longitudinal axes 在縱向方向允許對插偏差量

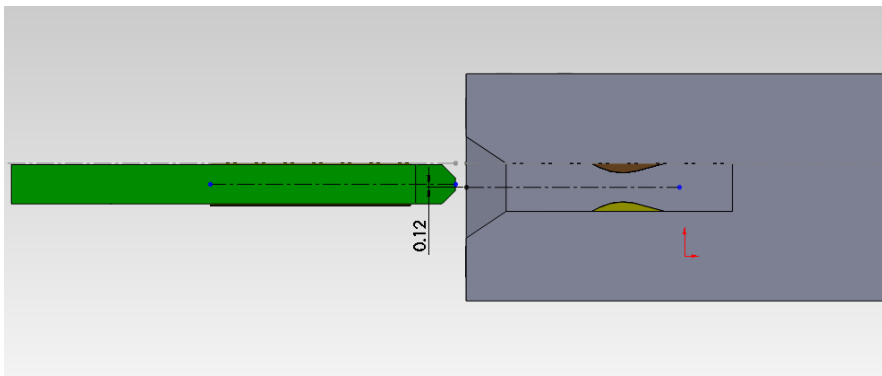

3.2.2 Inclination 傾向

The center and guiding in the Mpc OF THE FREE AND THE FIXED BOARD connector modules shall allow an initial angular misalignment of 2 FROM both the transverse and longitudinal axes

固定板連接器模件的在Mpc裡,連接器可接受橫向3° 和縱向2° 的最大傾斜對插角度。

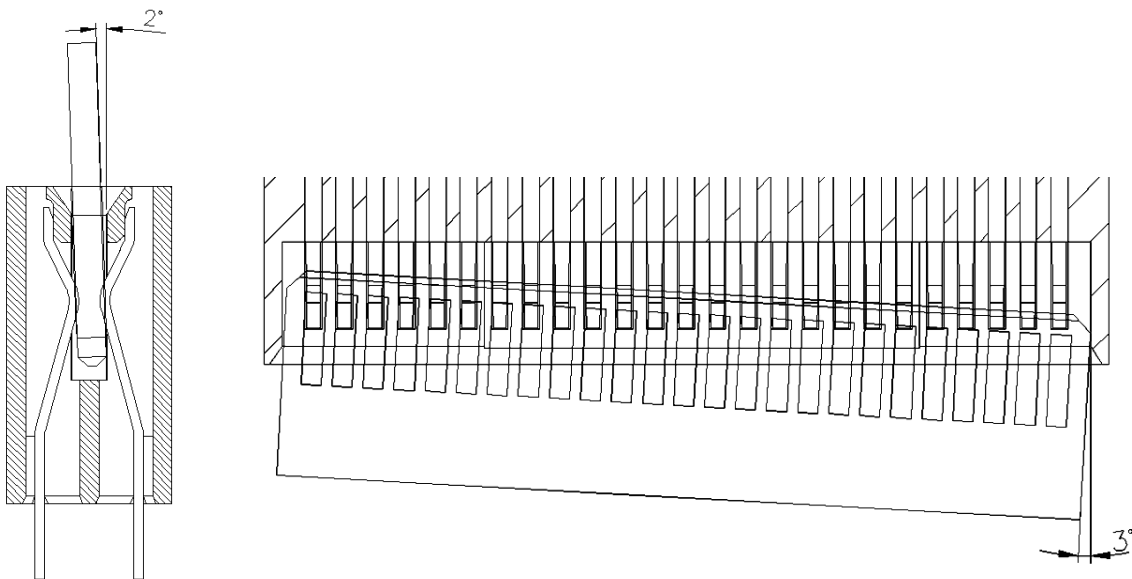

3.2.3 Capability for products wipe length

產品接觸長度等級



PRODUCT SPECIFICATION OF Oupin

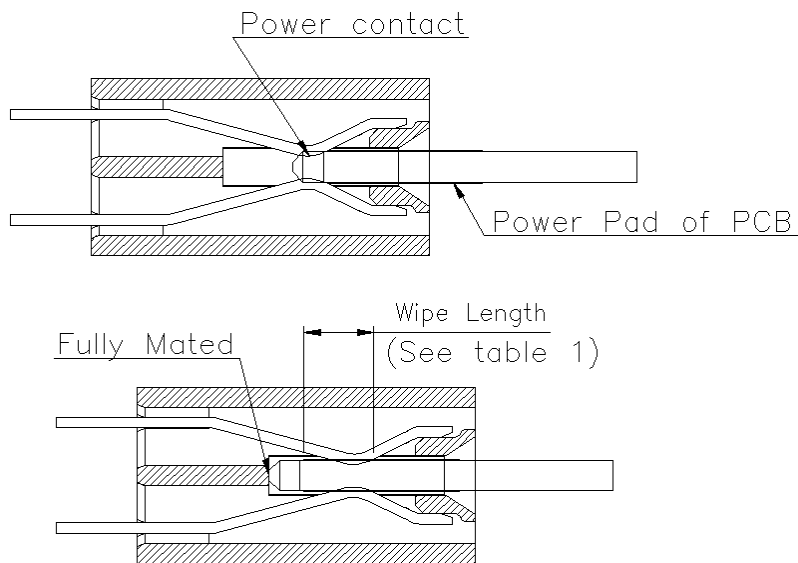

CONTACT	MATING LEVEL	WIPE LENGTH(MIN)
Power Pin	1	3.38mm

3.3. PCB/PANEL LAYOUT 印刷電路板佈局

The recommended PCB layout is shown in drawing.

本產品適用的 PCB layout 參見圖面。

3.4. BILL OF MATERIAL 材料清單

Harmful material controlling follows the requirements of RoHS. The bill of material is described in drawing.

有害物質控制符合RoHS指令要求。本產品使用的材料參見圖面。

3.5. MECHANICAL & ELECTRICAL CHARACTERISTIC 機械及電氣特性

The connector shall have the mechanical and electrical performance as described in drawing.

本產品的機械及電氣特性參見圖面。

3.6. PACKAGING 包裝

Products shall be packaged according to requirements specified in purchase order for safe delivery, connector container and the packaging method are shown in package specification.

產品可依客戶指定要求包裝，包裝材料與包裝方式參見產品包裝規範。

3.7 RATING CURRENT AND RATING VOLTAGE 額定電流與額定電壓

Rating current: Power pin 12.5A for UL



PRODUCT SPECIFICATION OF Oupin

額定電流: Power pin 12.5A for UL

Rating voltage is 12V DC RMS.

額定電壓 12V DC RMS。

3.8 TEMPERATURE RISE 溫升

1. Chart of Temperature rise vs current(series connection with all contact of SPEC)

加載電流對應溫升曲線圖(相同規格的所有 PIN 串聯起來)

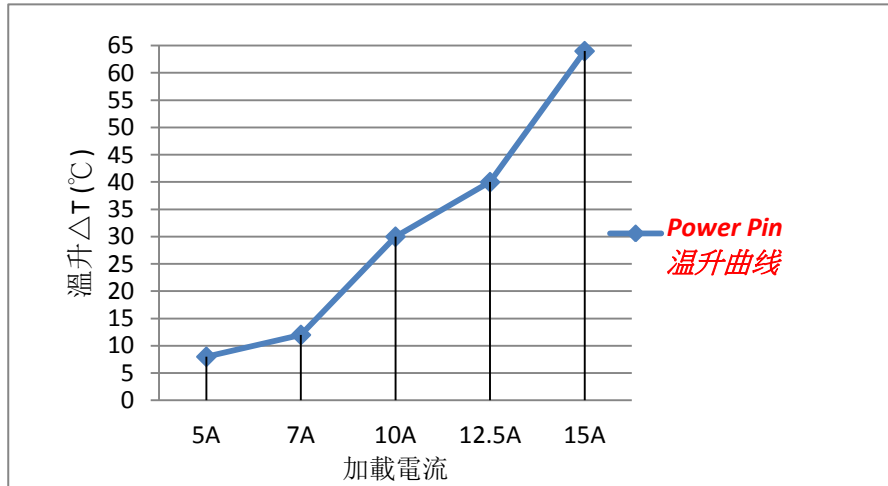

3.9 STORAGE AND OPERATING TEMPERATURE 存貯與使用溫度

Temperature range: $-5^{\circ}\text{C}\sim+105^{\circ}\text{C}$, including terminal temperature rise for rating current.

Storage Temperature : $0^{\circ}\text{C}\sim+40^{\circ}\text{C}$, Humidity: 80%RH under。

溫度範圍： $-5^{\circ}\text{C}\sim+105^{\circ}\text{C}$ ，包含接觸端子的額定電流溫升。

儲存溫度： $0^{\circ}\text{C}\sim+40^{\circ}\text{C}$ ，濕度：80%RH以下。

4. Environmental 環境要求

4.1. SOLDERABILITY 可焊性

Connectors meet solder-ability to MIL-STD-202, and shall be free of contaminants.

產品可焊性符合MIL-STD-202標準規定的相關要求，表面不得有污染物。

4.2. RESISTANCE TO SOLDER HEAT 耐焊接熱

4.1. WAVE SOLDER 波峰焊接

Each cycle consists of three consecutive phases. as shown in **Table II**.

每個焊接週期包括三個連續的階段，見附表二。

Note: 說明

Device temperature measurements are referenced from the top-center of the package outer surface.

設備溫度量測時以從頂部中間位置測量為準。



PRODUCT SPECIFICATION OF Oupiin

5. PERFORMANCE AND TEST DESCRIPTION 性能及測試

5.1. REQUIREMENT 要求

Product is designed to meet electrical, mechanical, and environmental performance requirements specified in **Table I**.

本產品設計符合附表一所列的機械，電氣及環境要求。

5.2. TEST CONDITION 測試條件

Unless otherwise specified, all tests shall be performed at ambient environmental conditions.

除非特別注明，所有測試在室溫條件下完成。

5.3. SAMPLE SELECTION 樣品選擇

Test samples shall be selected at random from current production. No test samples shall be reused. Samples are pre-conditioned with 10cycles of durability. Each group shall be containing 5 test samples at least.

測試樣品從現生產的產品中隨機抽取，所有測試過的樣品不得重複使用。樣品已預先插拔10次，每組測試至少有5個樣品。



PRODUCT SPECIFICATION OF Oupin

Table I: Test Requirements and Methods

附表一：測試要求與方法

Items 項目	Requirements 要求	Test Methods 測試方法
1. Confirmation of Product 產品確認	Product shall be conforming to the requirements of applicable product drawing. 產品必須符合相關產品圖面的要求。	Visually, dimensions and functionally inspected per applicable product drawing. 依相關產品圖面，檢查產品的外觀、尺寸及功能。
2. Contact Resistance 接觸阻抗	Power pin: 2.5 mΩ Max. initial. Contact resistance change Δ 1.5 mΩ Max Power pin 初始狀態 2.5mΩ Max, 接觸電阻變化值 Δ 1.5 mΩ Max Per EIA 364 TP06 適用：EIA 364 TP06	Subject mated contacts assembled in housing to closed circuit of 20 mA max , 20mV max. 所述固定端子連結到一個封閉回路中測試, 電流 20 mA max, 電壓 20 mV max 。
3. Insulation Resistance 絕緣阻抗	Power pin: 5000 MΩ Min. Power pin 最小 5000 MΩ. Per EIA 364-21 TP06 ,Condition B 適用：EIA 364 -21TP06, 條件 B	Measure by applying test potential between the adjacent contacts, and between the contacts and ground in the mated connector. (500 V DC \pm 10%). 測試產品相鄰端子間以及端子與接地間的電阻 (500 V DC \pm 10%) 。
4. Dielectric Withstanding Voltage 耐電壓	Power pin must withstand test potential of 1000 VAC RMS for 1 minute, current leakage must be 0.2mA Max. Power pin 必須承受測試電壓 1000 VAC RMS，時間 1 分鐘，漏電流不大於 0.2 mA 。	Measure by applying test potential between the adjacent contacts, and between the contacts and ground in the mated connector. 對產品相鄰端子間以及端子與接地間加載電壓，並測試其漏電流。
5. Durability (Repeated Mating/Un-mating) 耐久性	Contact Resistance: Rise in relation to initial values 1.5 mΩ max. After testing. 測試後接觸阻抗比初始值增大不超過 1.5 mΩ 。	Repeat mate and unmated for connector 200 cycles, at a speed of 25.4 mm per minute. 重復進行配合產品 200 次插拔，速度 25.4mm/分鐘。
6. Contact Retention Force	Power pin: 10N /Pin. Min. Power pin 每支最小 10N	Apply axial pull out force at a speed of 25.4 \pm 3 mm/minute on the contact assembled in the



PRODUCT SPECIFICATION OF Oupin

端子保持力	Per EIA-364-29 適用： EIA-364-29	housing. 以 25.4±3mm/分鐘的速度施加軸向拉力從塑膠本體上拔出端子。
7. Compliant Pin Insertion Force 压接力 Compliant Pin Retention Force 压接保持力	Into PCB Hold Force Per Pin: 55N Max 单 pin 压入 PCB 的力: 55N Max Per Pin Retention Force in PCB: 10N Min 单 Pin 在 PCB 中的保持力: 10N Min	At a speed of 25.4±3 mm/minute, Apply axial press in PCB to right position . 以 25.4±3mm/分鐘的速度，施加軸向壓力將端子壓入 PCB 板上。 at a speed of 25.4±3 mm/minute, Apply axial pull out from PCB to right position . 以 25.4±3mm/分鐘的速度施加軸向拉力從 PCB 板上拔出端子。
8. Mating /Un-mating Force 插入力/拔出力	Mating force:2N /pin Max. Un-mating force:0.2N /pin Min 插入力每 PIN 最大 2N 拔出力每 PIN 最小 0.2N Per EIA-364-37B 適用： EIA-364-37B	At a speed of 25.4±3 mm/minute, apply axial insert the mating part into fully or pull out from the subject product. 以 25.4±3 mm/分鐘的速度，軸向完全插入對配插件到被測產品中或從被測產品中拔出。
9. Vibration Sinusoidal Low Frequency 低頻正弦振動	No electrical discontinuity less than 1µs shall occur, Contact resistance: Rise in relation to initial values 1.5 mΩ Max. 不允許出現超過 1 µs 的瞬間斷開，測試後接觸阻抗比初始值增大不超過 1.5 mΩ 。 Per EIA-364-28. 適用： EIA-364-TP-28 。	Subject mated connector to 10-55-10 Hz traversed in 1 minute at 1.5mm amplitude, 15 minutes each of 3 mutually perpendicular planes, 10-55-10 Hz,振幅 1.5 mm 條件下，在互相垂直的三個面上，每個面 15 分鐘下測量，電流 10 mA 。
10. Thermal Shock 溫度沖擊	After testing, no damage, Contact Resistance: Rise in relation to initial Values 1.5 mΩ Max. Dielectric Strength should be OK; 測試後產品無損壞，接觸阻抗比初始值增大不超過 1.5 mΩ 。 Per EIA-364-32 適用： EIA-364-32	Temperature range from -55±3°C to +85±2°C. Start from -55°C, after 30 minutes, change to +85±2°C; change time is no more than 5 minutes, total 5 cycles. 溫度變化範圍： -55±3°C~ +85±2C。從 -55°C 開始，30 分鐘後換到+85°C，轉換時間不超過 5 分鐘，共 5 個循環。
11. Mechanical Shock 機械沖擊	Electrical discontinuity less than 1us. 电流瞬断时间小于 1us. Insulation Resistance Dielectric5000 MΩ Min and Power pin must withstand test potential of 1000 VDC RMS 絕緣阻抗 5000 MΩ Min, 耐電壓 1000VDC	速度 490m/s ² ; 半正弦波; 持续 11 毫秒; ±X, ±Y, ±Z, 方向各 3 次; Accelerate Velocity:490m/s ² ; Waveform:Half-sine shock plus; Duration:11msec; 3drops each to normal and reversed directions of X,Y and Z axes;



PRODUCT SPECIFICATION OF Oupin

<p>12. Humidity- Temperature Cycle 溫濕度循環</p>	<p>After testing, no damage, Contact Resistance: Rise in relation to initial Values 1.5 mΩ Max. Dielectric Strength should be OK 測試後產品無損壞，接觸阻抗比初始值增大不超過 1.5 mΩ。</p> <p>Per EIA-364-31B 適用：EIA-364-31B</p>	<p>Subject product to -25~65°C, 90-95%.R.H 10Cycles. 產品置於-25~65°C,相對濕度：90-95%,循環 10 次</p>
<p>13. Salt Spray 鹽霧</p>	<p>After testing, no damage, Contact Resistance: Rise in relation to initial Values 1.5 mΩ Max. Dielectric Strength should be OK. 測試後產品無損壞，接觸阻抗比初始值增大不超過 1.5 mΩ。</p> <p>Per MIL-STD-202, Method 101, condition B 適用：MIL-STD-202，方法 101，條件 B。</p>	<p>5±1% salt concentration 48 hours 35±2°C 鹽水濃度 5±1%，時間 48 小時，溫度 35±2°C。</p>
<p>14.High Temperature Life 高溫老化</p>	<p>After testing, no damage, Contact Resistance: Rise in relation to initial Values 1.5 mΩ Max. Dielectric Strength should be OK; 測試後產品無損壞，接觸阻抗比初始值增大不超過 1.5 mΩ。</p> <p>Per EIA-364-17 Method A 適用：EIA-364-17，條件 A。</p>	<p>Subject product to 105±3°C for 250 hours continuously. 產品置於 105±3°C 連續 250 小時。</p>
<p>15. Solderability 可焊性</p>	<p>There shall have a solder coverage of 95% minimum。 產品在測試完成後，焊接部位粘錫面積大於 95%。</p>	<p>Soldering time: 4 to 6 seconds. Temperature: 260±5°C. 焊接時間：4~6 秒。 溫度：260±5°C。</p>



PRODUCT SPECIFICATION OF Oupiin

Table II : Weld the curve graph in crest

附表二：波峰焊曲線圖

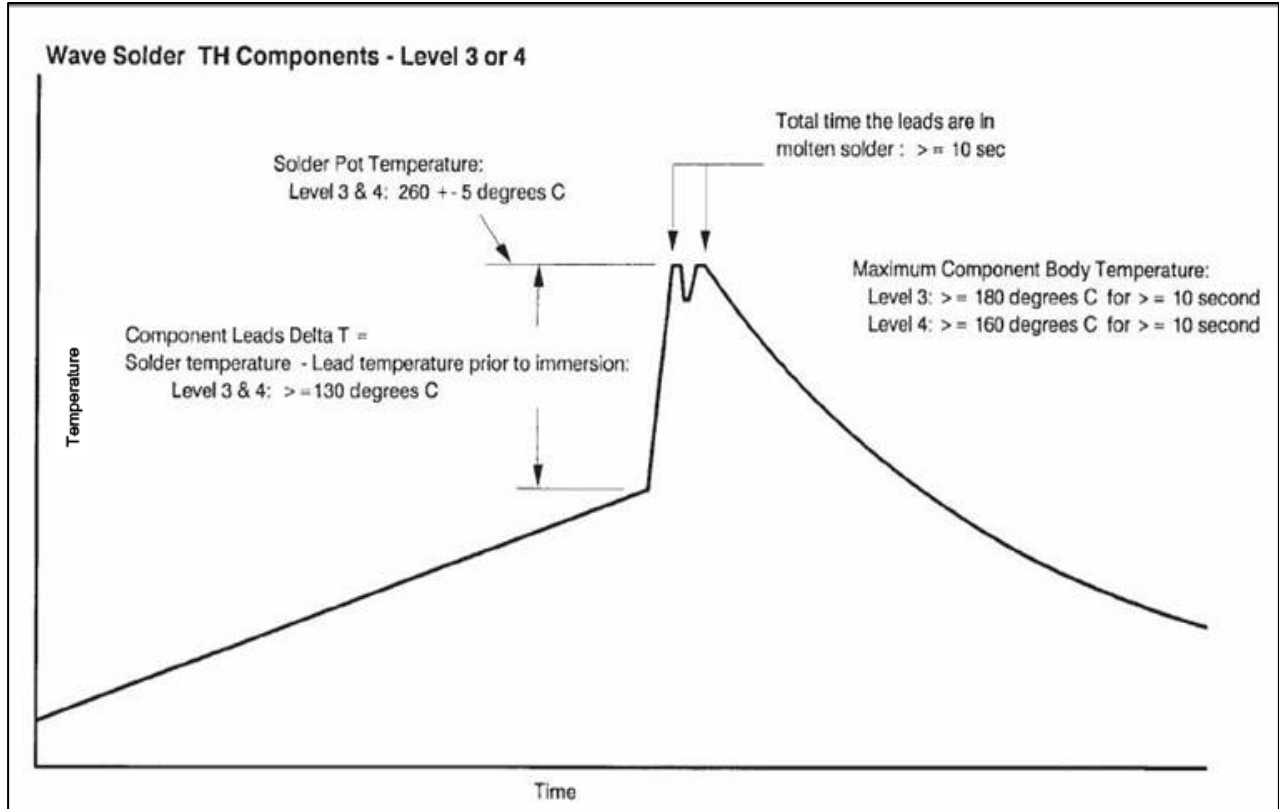



PRODUCT SPECIFICATION OF Oupin

Material Housing : 069-LCP(Black)

[SGS Test Report Click here](#)

[如需 SGS 測試報告請點選此處](#)

長春人造樹脂廠股份有限公司

台北市 10477 松江路三 0 一號七樓

CHANG CHUN PLASTICS CO.,LTD.

CABLE ADDRESS :
LONGLITE TAIPEI
TLX:22535 LONGLITE

No.301, SONGKIANG ROAD, 7TH FL.,
TAIPEI, 10477 TAIWAN

TEL: (02)2503-8131 (REP)
FAX: (02)2503-3378

Technical Data

Liquid Crystalline Polymer Compound

LONGLITE[®] LCP 270B3G / 270N3G

LCP-270B(N)3G is liquid crystalline polymer which contains 30% glass fiber.

LCP-270B(N)3G has advantages of high heat resistance, strength and good flowability.

Physical Properties :

Items	Unit	Test Method	270B3G* 270N3G
Features	heat resistance/low warpage		
Filler	%	---	Glass Fiber
Filler Content		ASTM	30
Specific Gravity	---	D792	1.62
Water Absorption	%	D570	0.04
Shrinkage	MD	CCP method	0.19
	TD		0.39
Tensile Strength(RT)	MPa	D638	122
Tensile Elongation(RT)	%		1.8
Flexural Strength (RT)	MPa	D790	190
Flexural Modulus (RT)	GPa		12.5
Izod Impact (3.0t/w notched)	J/m	D256	110
HDT (264 psi)	°C	D648	270
Dielectric Strength	KV/mm	D149	19
Arc Resistance	sec	D495	150
UL-94(NC, BK)	Rating	UL94	V-0
Tracking Resistance (CTI)	V	D257	125
Dielectric Constant / Dk	---	10 ⁶ Hz (1 MHz)	4.5
Dielectric Tangent / Df	---	10 ⁶ Hz (1 MHz)	0.036

* Typical data : Not to be constructed as specification

LCP-270B(N)3G B : Black N : Natural color



PRODUCT SPECIFICATION OF Oupin

Material Housing :UL

UL iQ™ for Plastics

Page 1 of 1

Component - Plastics

E59481

CHANG CHUN PLASTICS CO LTD

7TH FL, 301 SONGKIANG RD, TAIPEI 104 TW

270(X1)3G

Liquid Crystal Polymer (LCP), "LONGLITE", furnished as pellets

Color	Min Thk (mm)	Flame Class	HWI	HAI	RTI Elec	RTI Imp	RTI Str
BK	0.3	V-0	4	0	130	130	130
	1.0	V-0	2	0	130	130	130
	3.0	V-0	0	0	130	130	130

Comparative Tracking Index (CTI): 4

Inclined Plane Tracking (IPT): -

Dielectric Strength (kV/mm): -

Volume Resistivity (10¹² ohm-cm) : -

High-Voltage Arc Tracking Rate (HVTR): 2

High Volt, Low Current Arc Resis (D495): 5

Dimensional Stability (%): -

(X1) - Maybe replace by one letter N representing Natural color or B representing Black color

ANSI/UL 94 small-scale test data does not pertain to building materials, furnishings and related contents. ANSI/UL 94 small-scale test data is intended solely for determining the flammability of plastic materials used in the components and parts of end-product devices and appliances, where the acceptability of the combination is determined by UL.

Report Date:2013-07-12
Last Revised:2013-07-12

© 2013 UL LLC



IEC and ISO Test Methods

Test Name	Test Method	Units	Thickness Tested (mm)	Value
Flammability	IEC 60695-11-10	Class (color)	0.3	V-0 (BK)
			1.0	V-0 (BK)
			3.0	V-0 (BK)
Glow-Wire Flammability (GWFI)	IEC 60695-2-12	C	-	-
Glow-Wire Ignition (GWIT)	IEC 60695-2-13	C	-	-
IEC Comparative Tracking Index	IEC 60112	Volts (Max)	-	-
IEC Ball Pressure	IEC 60695-10-2	C	-	-
ISO Heat Deflection (1.80 MPa)	ISO 75-2	C	-	-
ISO Tensile Strength	ISO 527-2	MPa	-	-
ISO Flexural Strength	ISO 178	MPa	-	-
ISO Tensile Impact	ISO 8256	kJ/m ²	-	-
ISO Izod Impact	ISO 180	kJ/m ²	-	-
ISO Charpy Impact	ISO 179-2	kJ/m ²	-	-

© 2013 UL LLC



PRODUCT SPECIFICATION OF Oupin

Material Power Pin : Copper Alloy (C18400)

[SGS Test Report Click here](#)

[如需 SGS 測試報告請點選此處](#)



INSPECTION REPORT

客戶名稱 CUSTOMER	弘振企業股份有限公司
------------------	------------

鎧蔚企業有限公司
METALEX ENTERPRISE CO., LTD
 No.108-3, Sec. 1, Guangfu Rd., SanChong District,
 New Taipei City 24158, Taiwan
 TEL : +886-2-2278-1989 FAX : +886-2-2999-9687

品名 PRODUCT	C18400-R540	母料號碼 LOT NO	C09I12-1F	日期 DATE	2014/10/23
規格 SIZE	0.64 X 310	重量 QUANTITY	1454 KG	序號 NO.	131000015

化學成份 CHEMICAL COMPOSITION

成分符號 ELEMENT	Cu	CR	ZR						
規格 SPEC (%)	MIN	0.2	0.03						
	MAX	1.2	0.3						
分析值 ANALYSIS VALUE	99.2250	0.5686	0.1509						

機械特性試驗 MECHANICAL TESTING

項目 ITEM	抗拉強度 Tensile Strength N/mm ²	屈服強度 Yield Strength N/mm ²	伸長率 Elongation %	導電率 Electrical Conductivity %IACS	硬度 Hardness (for reference only) HV
規格 SPEC	MIN	540	500	4	83
	MAX	630			190
實測值 MEASURED VALUE	555	510	9.5	90.12	156

尺寸量測 GEOMETRICAL DIMENSIONS

項目 ITEM	厚度 Thickness (mm)	寬度 Width (mm)	粗糙度 Ra um		
規格 SPEC	MIN	0.610	309		
	MAX	0.670	311	0.15	
實測值 MEASURED VALUE	0.640	310	0.07-0.08		

備註 REMARKS

*厚度 ≤ 0.12T 以下者, 硬度僅供參考.

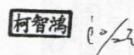
	責任者	品質擔當者
	 Theresa 2014.10.23 黃秀玲	 柯智鴻 10/23

