

歐品電子(昆山)有限公司

OUPIIN ELECTRONIC(KUNSHAN) CO.,LTD.

PACKAGING SPECIFICATION (包裝作業規範)

tray

CONFIDENTIAL TOP SECRET

PAGE 1/4 REV. Q

SPEC.NO.(規範編號)	Q3011SPP-042	APPLICABLE CUSTOMER (適用客戶)	ALL	APPLICABLE PRODUCT (適用產品)	3011-xxxxxSxxA	3011-64xxA/Z	PACKAGING CATEGORY (包裝方式)	TRAY PLATE PACKING
----------------	--------------	----------------------------	-----	---------------------------	----------------	--------------	---------------------------	--------------------

REVISION HISTORY (修訂履歷)

REV.	ECN NO	PAGE (頁次)				
		1	2	3	4	
K		Alteration mode (變更包裝方式)				
L		(更改包箱盤數)				
M		Change the packaging one to count (更改包箱盤數)				
N		Change Quantity (變更包裝層數)				
P		Add direction description of product in tray. (增加擺盤描述)				(修改第二頁的視圖，更新短羊角產品的擺盤方式)
Q		Change the packaging one to count (更改包箱盤數)				包裝盒數量由30盤/每箱改為28盤/每箱。

DIVISION (事業單位)	Product Develop (產品開發課)	APPROVED (核准)	CHECKED (審核)	PE: DE:	PREPARED (制表)	LIYUN 8/2/22
-----------------	-------------------------	---------------	--------------	------------	---------------	--------------

歐品電子(昆山)有限公司

OUPIIN ELECTRONIC(KUNSHAN) CO.,LTD.

PACKAGING SPECIFICATION (包裝作業規範)

■ CONFIDENTIAL □ TOP SECRET

SPEC.NO.(規範編號) Q3011SPP-042

PAGE 2/4 REV. Q

PACKING OPERATION DIAGRAM & INSTRUCTION (包裝作業圖示及說明)

REMARK (備注)

Laying Product Diagram:
(產品擺放圖示)

(产品羊角为短羊角时，产品尽可能的靠近tray盘下边缘如下图)

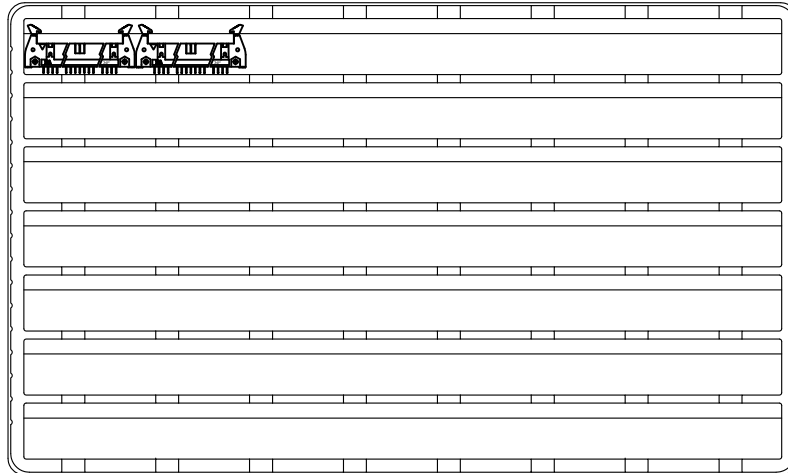

一.PVC Plate Packing Mode:

(PVC盤包裝方式)

(1).CT-1.6 Box: PVC-07 30PCS.

(CT-1.6 規格的紙箱放PVC-07盤 30PCS)

(2).Put product in each trough fully as shown in diagram.

(產品在盤子中擺放方式如圖所示)

(3).After filling each trough with product fully,cover it with transparent upper cover PVC-073 1PCS。

(每箱放滿產品後,加蓋透明上蓋 PVC-073 1PCS)

(4).Stack the XX PVC plates filled with product, put them in the paper box in which has been put waterproof bag.

(將放滿產品的XX個PVC盤疊起,裝入防水袋放入紙箱內)

歐品電子(昆山)有限公司

OUPIIN ELECTRONIC(KUNSHAN) CO.,LTD.

PACKAGING SPECIFICATION (包裝作業規範)

<input checked="" type="checkbox"/> CONFIDENTIAL <input type="checkbox"/> TOP SECRET	
PAGE	3/4
REV.	Q

SPEC.NO.(規範編號) Q3011SPP-042

PACKING OPERATION DIAGRAM & INSTRUCTION (包裝作業圖示及說明)

REMARK (備注)

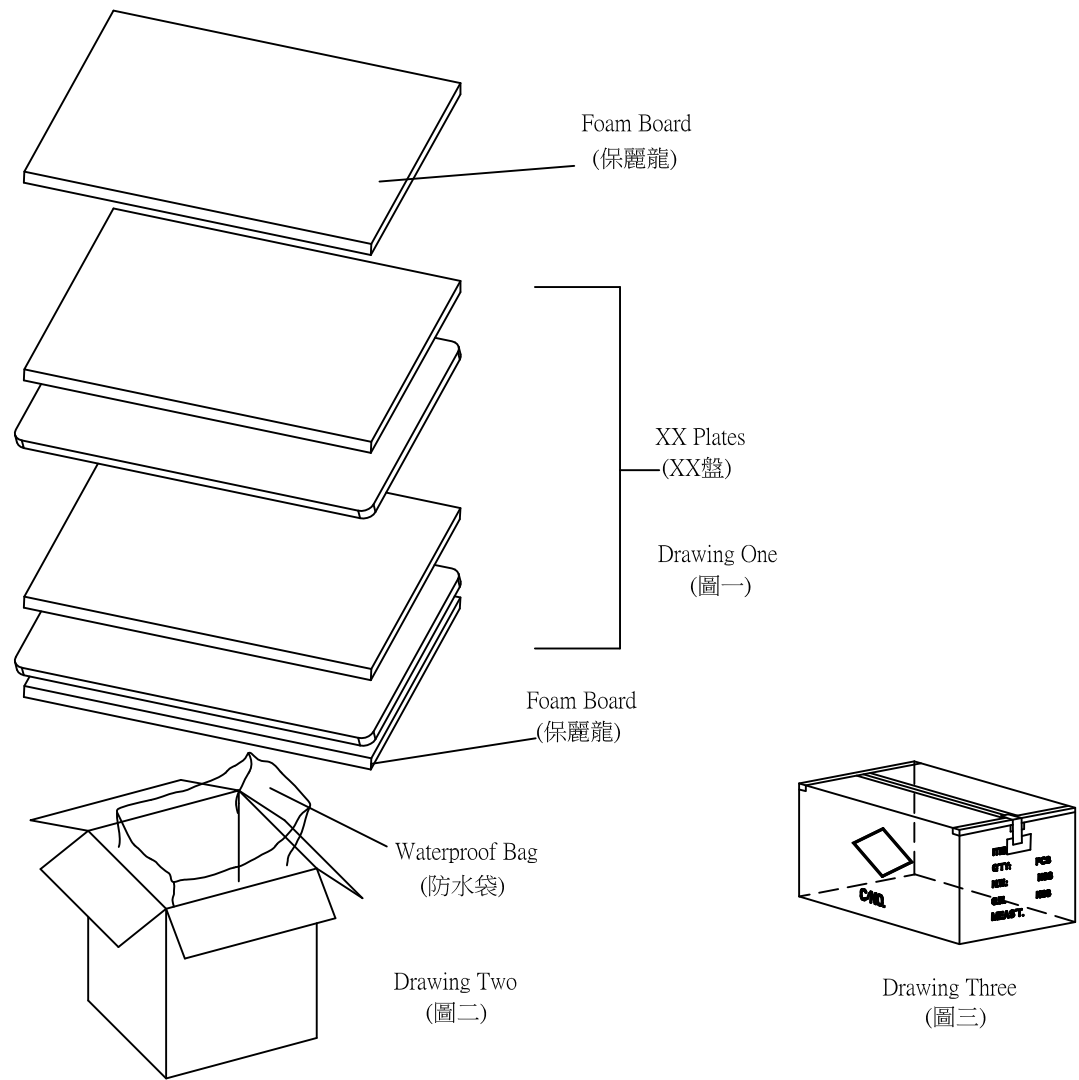

- 一. Outer Box Packing Mode:
(外箱包裝方式)
- (1). Paper box 1.9 or 1.6 standard 1 PCS, as shown in drawing Two.
(紙箱 1.9 或 1.6 規格 1 PCS. 如(圖二)所示)
 - (2). Put one Foam Board in the upper and lower of the paper box, 2PCS in all, as shown in drawing One.
(每箱上下各放一塊保麗龍, 共 2PCS, 如(圖一)所示)
 - (3). Put 1 PCS waterproof in the paper box, as shown in drawing Two.
(紙箱內側放入防水袋 1 PCS. 如(圖二)所示)
 - (4). Piled the XX packing plates packed up in the waterproof.
(將放滿產品的 XX 個 PVC 盤疊起, 裝入防水袋內)
 - (5). Seal the waterproof bag, then put the Foam Board 1PCS on the bag.
(Put 1 PCS Foam Board at the right and left side in the paper box if it is necessary.)
(封上防水袋, 然後放上第二塊保麗龍薄板)
(必要時, 在紙箱的左右兩側各放一塊保麗龍)
 - (6). Seal the surface of the outer box, as shown in drawing Three.
(將外箱上層封口. 如(圖三)所示)
- The form on the right and flank side of the box must be filled correctly and clearly, take actual testing weight as the standard of each box gross weight.
- 外箱之正麥和側麥所要填寫之項目要填寫正確, 清晰, 每箱之毛重應以實測重量為準.

歐品電子(昆山)有限公司

OUPIIN ELECTRONIC(KUNSHAN) CO.,LTD.

PACKAGING SPECIFICATION (包裝作業規範)

CONFIDENTIAL TOP SECRET

SPEC.NO.(規範編號)		Q3011SPP-042									
PACKING MATERIAL (包裝材料)		PRODUCT P/N		CT NO.		PACKING N.W.		PACKING QUANTITY (包裝數量)		WEIGHT (重量) kg	
MATERIAL NAME (材料名稱)	PART NO. (料號)	Q'TY	(產品料號)	(紙箱規格)	(包材重量)	PCS/TRAY	TRAY/BOX	PCS/BOX	N.W./PCS	N.W./BOX	G.W./BOX
PAPER BOXES (紙箱)	CT-1.6	1	3011-10xxxSx(1,2)A	CT-1.6	5.30	84	28	2352	0.004100	9.64	14.94
Packing Box (包裝盒)	PVC-07	----	3011-14xxxSx(1,2)A	CT-1.6	5.30	70	28	1960	0.005740	11.25	16.55
			3011-16xxxSx(1,2)A	CT-1.6	5.30	70	28	1960	0.006560	12.86	18.16
			3011-20xxxSx(1,2)A	CT-1.6	5.30	63	28	1764	0.008200	14.46	19.76
			3011-26xxxSx(1,2)A	CT-1.6	5.30	49	28	1372	0.010660	14.63	19.93
Packing Box Cover (包裝盒蓋子)	PVC-073	1	3011-30xxxSx(1,2)A	CT-1.6	5.30	49	28	1372	0.012300	16.88	22.18
			3011-34xxxSx(1,2)A	CT-1.6	5.30	42	28	1176	0.013940	16.39	21.69
			3011-40xxxSx(1,2)A	CT-1.6	5.30	35	28	980	0.016400	16.07	21.37
WATERPROOF BAG (防水袋)	PE 100*90	1	3011-50xxxSx(1,2)A	CT-1.6	5.30	28	28	784	0.020500	16.07	21.37
			3011-60xxxSx(1,2)A	CT-1.6	5.30	28	28	784	0.024600	19.29	24.59
			3011-64xxxSx(1,2)A	CT-1.6	5.30	28	28	784	0.026240	20.57	25.87
Foam (保麗龍)	-----	2	3011-64xxA/Z	CT-1.6	5.30	28	28	784	0.009450	7.41	12.71
DRYING AGENT (干燥劑)	-----	3									

I.NOTE:

(注意)

When the finished products have been made,take the actual weight as the standard of gross weight in each box.

(成品出貨時,每箱之毛重應以實測重量為準)

When the finished products have been made,stick the proper designation list on the box according to product demand.

(成品出貨時,依據出貨要求貼上相對應的標籤單)