

歐品電子(昆山)有限公司

OUPIIN ELECTRONIC(KUNSHAN) CO.,LTD.

PACKAGING SPECIFICATION (包裝作業規範)

CONFIDENTIAL TOP SECRET

SPEC.NO.(規範編號) Q9391SPP-1122		APPLICABLE PRODUCT (適用產品) 9391-A2P04S08P04CB30PA		PAGE 1/4	REV. B
APPLICABLE CUSTOMER (適用客戶) ALL				PACKAGING CATEGORY (包裝方式) TRAY PLATE PACKING	

REVISION HISTORY (修訂履歷)

ECN REV. NO	PAGE (頁次)								
	1	2	3	4					
A	New Issue 新版發行								
B	Change Paper Box 修改紙箱規格								

DIVISION (事業單位) Product Development (產品開發課)	APPROVED (核准)	CHECKED (審核)	DE: PE:	PREPARED (制表)	zcc 06/08'20
---	---------------	--------------	---------	---------------	--------------

歐品電子(昆山)有限公司

OUPIIN ELECTRONIC(KUNSHAN) CO.,LTD.

PACKAGING SPECIFICATION (包裝作業規範)

SPEC.NO.(規範編號) Q9391SPP-1122

<input checked="" type="checkbox"/> CONFIDENTIAL	<input type="checkbox"/> TOP SECRET		
PAGE	2/4	REV.	B

PACKING OPERATION DIAGRAM & INSTRUCTION (包裝作業圖示及說明)

REMARK (備注)

Laying Product Diagram:
(產品擺放圖示)

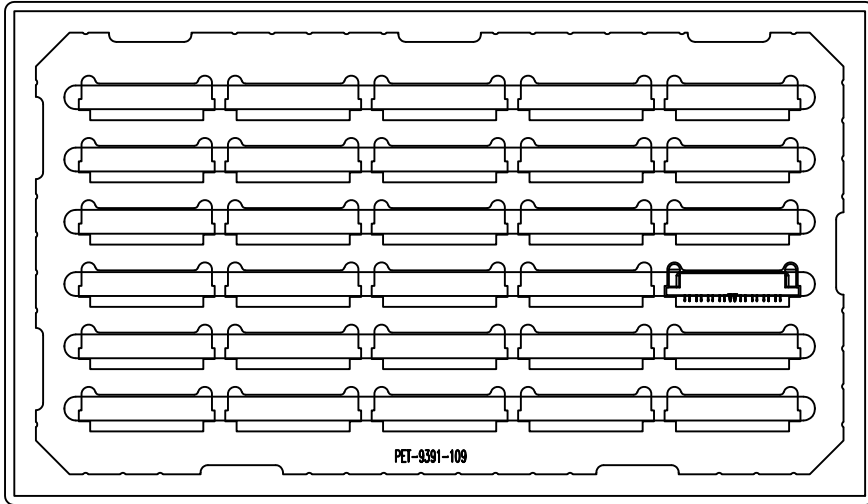

- 一.PVC Plate Packing Mode:
(PVC盤包裝方式)
 - (1) CT-0.9 Box: 9391-PET-109 xx PCS.
(CT-0.9 規格的紙箱放9391-PET-109 xx PCS)
 - (2).Put product in each trough fully as shown in diagram.
(產品在盤子中擺放方式如圖所示)
 - (3).After filling each trough with product fully,cover it with transparent upper cover 9391-PET-110 1PCS。
(每盤放滿產品後,加蓋透明上蓋 9391-PET-110 1PCS)
 - (4).Stack the xx PVC plates filled with product, put them in the paper box in which has been put waterproof bag.
(將放滿產品的xx個PVC盤疊起,裝入防水袋放入紙箱內)

歐品電子(昆山)有限公司

OUPIIN ELECTRONIC(KUNSHAN) CO.,LTD.

PACKAGING SPECIFICATION (包裝作業規範)

<input checked="" type="checkbox"/> CONFIDENTIAL		<input type="checkbox"/> TOP SECRET	
PAGE	3/4	REV.	B

SPEC.NO.(規範編號) Q9391SPP-1122

PACKING OPERATION DIAGRAM & INSTRUCTION (包裝作業圖示及說明)

REMARK (備注)

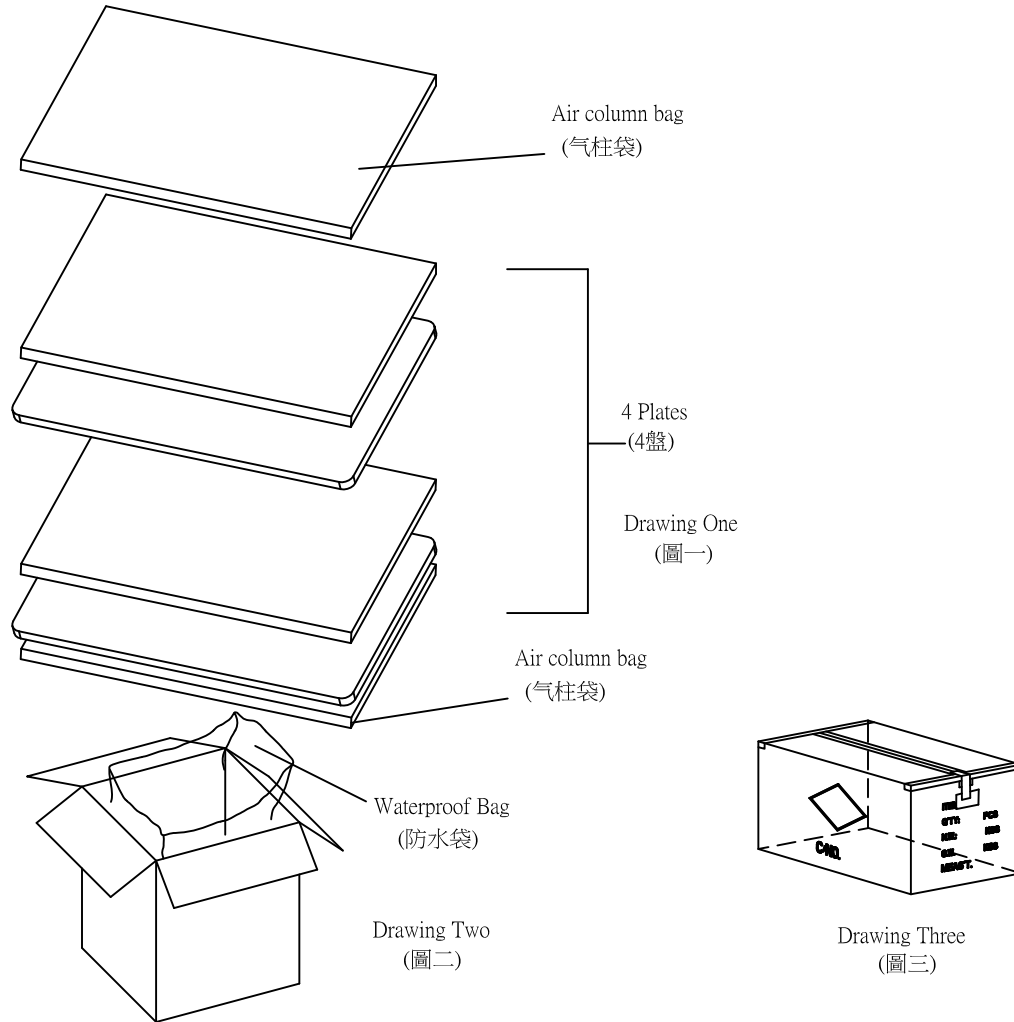

一. Outer Box Packing Mode:

(外箱包裝方式)

- (1). Paper box 0.9 standard 1 PCS, as shown in drawing Two.
(紙箱0.9規格 1 PCS, 如(圖二)所示)
- (2). Put one Air column bag in the upper and lower of the paper box, 2PCS in all, as shown in drawing One.
(每箱上下各放一塊气柱袋, 共2PCS, 如(圖一)所示)
- (3). Put 1 PCS waterproof in the paper box, as shown in drawing Two.
(紙箱內側放入防水袋 1 PCS, 如(圖二)所示)
- (4). Piled the 4 PVC plates packed up in the waterproof.
(將放滿產品的4個PVC盤疊起, 裝入防水袋內)
- (5). Seal the waterproof bag, then put the Air column bag 1PCS on the bag.
(Put 1 PCS Air column bag at the right and left side in the paper box if it is necessary.)
(封上防水袋, 然後放上第二塊气柱袋)
(必要時, 在紙箱的左右兩側各放一塊气柱袋)
- (6). Seal the surface of the outer box, as shown in drawing Three.
(將外箱上層封口, 如(圖三)所示)

The form on the right and flank side of the box must be filled correctly and clearly, take actual testing weight as the standard of each box gross weight.

外箱之正麥和側麥所要填寫之項目要填寫正確, 清晰, 每箱之毛重應以實測重量為準.

歐品電子(昆山)有限公司

OUPIIN ELECTRONIC(KUNSHAN) CO.,LTD.

PACKAGING SPECIFICATION (包裝作業規範)

CONFIDENTIAL TOP SECRET

PAGE: 4/4 REV. B

SPEC.NO.(規範編號)			PRODUCT P/N			PACKING N.W.			PACKING QUANTITY (包裝數量)			WEIGHT (重量) kg																							
MATERIAL NAME (材料名稱)			(產品料號)			(包材重量)			PCS/TRAY			TRAY/BOX			PCS/BOX			N.W./PCS			N.W./BOX			G.W./BOX											
PAPER BOXES (紙箱)			CT-0.9			1			9391-A2P04S08P04CB30PA			CT-0.9			4.39			30			12			360			0.0351688			12.66			17.05		
Packing Box (包裝盒)			9391-PET-109			----																													
Packing Box Cover (包裝盒蓋子)			9391-PET-110			----																													
WATERPROOF BAG (防水袋)			PE 100*70			1																													
Air column bag (气柱袋)			-----			2																													
DRYING AGENT (干燥劑)			-----			3																													

1.NOTE:
(注意)
When the finished products have been made,take the actual weight as the standard of gross weight in each box.(成品出貨時,每箱之毛重應以實測重量為準)
When the finished products have been made,stick the proper designation list on the box according to product de

2.NOTE:
(注意)
*Pay attention to each big reel of material ,can be divided into 3 small reels,consumption of each big reel can't exceed 1 meter, or the third reel can't be packed
(來料每大卷reel (carrier tape) 平均可分3小卷reel , 每大卷reel 消耗量不可超過1米,否則第三小卷不可包裝.)