

歐品電子(昆山)有限公司

OUPIIN ELECTRONIC(KUNSHAN) CO.,LTD.

PACKAGING SPECIFICATION (包裝作業規範)

SPEC.NO.(規範編號)	7908SPP	適用產品: 7908-09FTN2A	PAGE	1/1	REV.	I767
----------------	---------	--------------------	------	-----	------	------

PACKING OPERATION DIAGRAM & INSTRUCTION (包裝作業圖示及說明)

REMARK (備註)

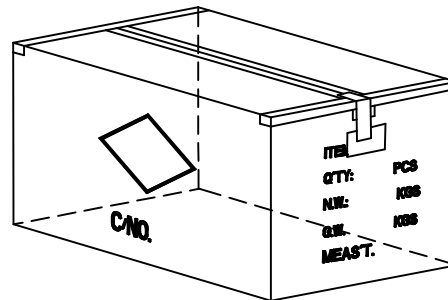
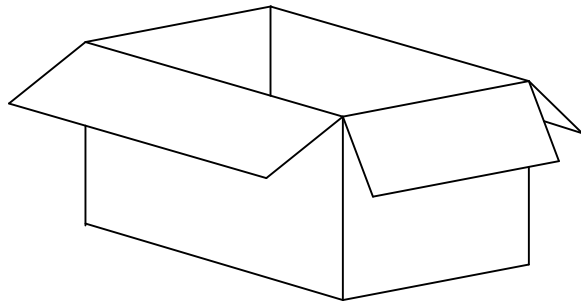
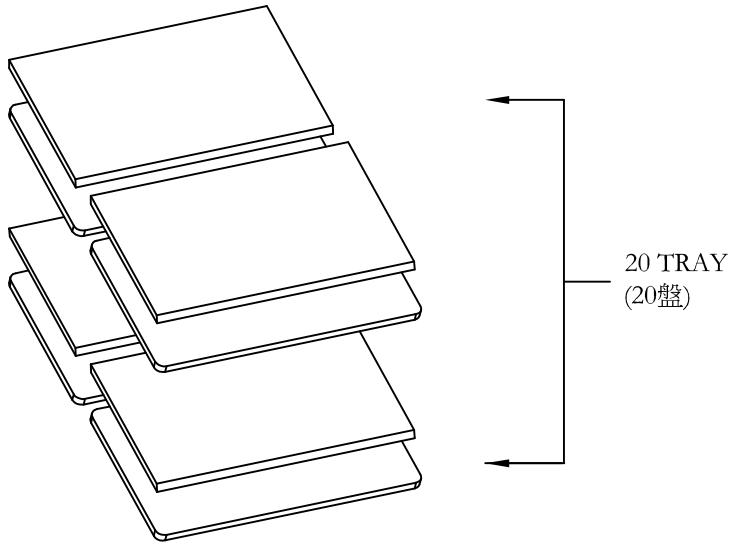

CT-0.53: 357(mm)X200(mm)X218(mm)

Packing:
50 PCS/ TRAY
1K PCS/ CARTON
20 TRAY/ CARTON

CARTON:
N.W. = 5Kg
G.W. = 5.5 Kg

Drawn By: Jerry 10/28'19