

歐品電子(昆山)有限公司

OUPIIN ELECTRONIC(KUNSHAN) CO.,LTD.

PACKAGING SPECIFICATION (包裝作業規範)

| | | | | | | |
|----------------|---------|----------------------|------|-----|------|------|
| SPEC.NO.(規範編號) | 5100SPP | 適用產品: 5100-MxC06R01T | PAGE | 1/1 | REV. | I619 |
|----------------|---------|----------------------|------|-----|------|------|

PACKING OPERATION DIAGRAM & INSTRUCTION (包裝作業圖示及說明)

REMARK (備註)

24 Empty carrier tape 16 Empty carrier tape

200Pcs

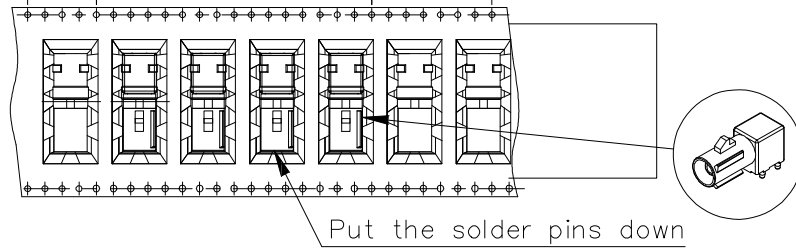

Cardboard for Upper & Lower

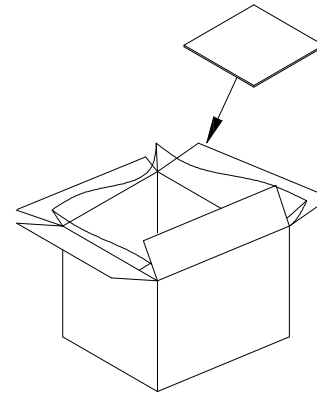

Carton: 350(mm)X350(mm)X325(mm)

Pull out direction

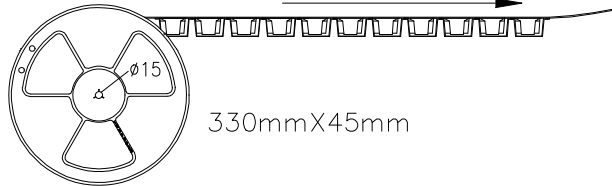

Compression bag

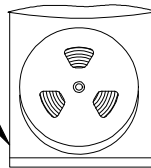

Triangle partition

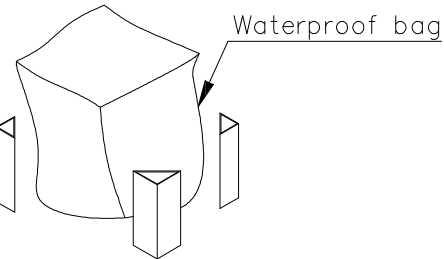

Packing:
200 Pcs/Reel
6 Reel/Carton
1200 Pcs/Carton

Drawn By: Martin 12/15'22