

# 歐品電子(昆山)有限公司

OUPIIN ELECTRONIC(KUNSHAN) CO.,LTD.

## PACKAGING SPECIFICATION (包裝作業規範)

CONFIDENTIAL  TOP SECRET

SPEC.NO.(規範編號) Q9001SPP-339T1

PAGE 1/4 REV. Q

APPLICABLE CUSTOMER (適用客戶) ALL

APPLICABLE PRODUCT (適用產品) 9001-16xx(1/2)Cxx(L1)A

PACKAGING CATEGORY (包裝方式) TRAY PLATE PACKING

### REVISION HISTORY (修訂履歷)

ECN REV. NO	PAGE (頁次)			
	1	2	3	4
K	Revise the quantity of the packing (修改包裝數量)			
L	Add P/N (新增料号)			
M	Cancel upper cover change to empty chassis (取消上蓋變更為空底盤)			
N	Modification Plate Install Cover Explain (修改盤子包裝說明)			
P	change empty tray to upper cover (空盤改為上蓋)			
R	Revise the quantity of the paking (修改包裝盤數量)			
	(26盤/箱改為25盤/箱)			

DIVISION (事業單位)	Product Development (產品開發課)	APPROVED (核准)	Peter Zhu	CHECKED (審核)	Nita Lu	PREPARED (制表)	Martin 04/26'23
-----------------	-----------------------------	---------------	-----------	--------------	---------	---------------	-----------------

# 歐品電子(昆山)有限公司

OUPIIN ELECTRONIC(KUNSHAN) CO.,LTD.

PACKAGING SPECIFICATION (包裝作業規範)

SPEC.NO.(規範編號) Q9001SPP-339T1

■ CONFIDENTIAL □ TOP SECRET

PAGE

2/4

REV.

Q

PACKING OPERATION DIAGRAM & INSTRUCTION (包裝作業圖示及說明)

REMARK (備注)

Laying Product Diagram:

(產品擺放圖示)



一.PVC Plate Packing Mode:  
(PVC盤包裝方式)

(1).CT-1.6 Box: PVC-10 XX PCS.

(CT-1.6 規格的紙箱放PVC-10盤 XX PCS)

(2).Put product in each trough fully as shown in diagram.  
(產品在盤子中擺放方式如圖所示)

(3).After filling each trough with product fully,cover it  
with transparent upper cover PVC-073-1 1PCS.  
(每箱放滿產品後,加蓋透明上蓋 PVC-073-1 1PCS)

(4).Stack the XX PVC plates filled with product, put them in  
the paper box in which has been put waterproof bag.  
(將放滿產品的XX個PVC盤疊起,裝入防水袋放入紙箱內)

# 歐品電子(昆山)有限公司

OUPIIN ELECTRONIC(KUNSHAN) CO.,LTD.

PACKAGING SPECIFICATION (包裝作業規範)

<input checked="" type="checkbox"/> CONFIDENTIAL		<input type="checkbox"/> TOP SECRET	
PAGE	3/4	REV.	Q

SPEC.NO.(規範編號) Q9001SPP-339T1

## PACKING OPERATION DIAGRAM & INSTRUCTION (包裝作業圖示及說明)

## REMARK (備注)

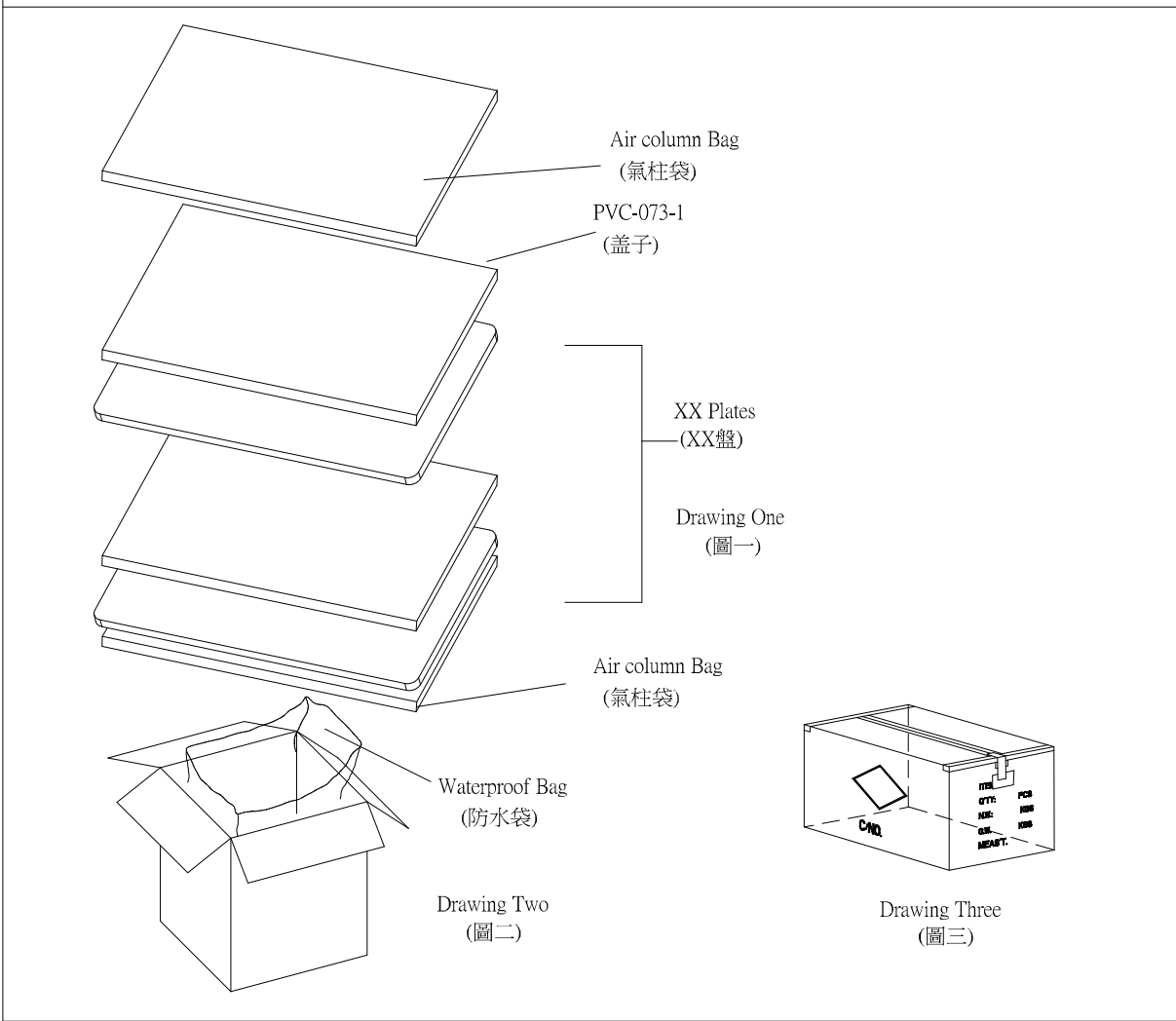

- 一. Outer Box Packing Mode:  
(外箱包裝方式)
- (1). Paper box 1.9 or 1.6 standard 1 PCS, as shown in drawing Two.  
(紙箱 1.9 或 1.6 規格 1 PCS, 如(圖二)所示)
  - (2). Put one Air column bag in the upper and lower of the paper box, 2PCS in all, as shown in drawing One.  
(每箱上下各放一塊氣柱袋, 共 2PCS, 如(圖一)所示)
  - (3). Put 1 PCS waterproof in the paper box, as shown in drawing Two.  
(紙箱內側放入防水袋 1 PCS, 如(圖二)所示)
  - (4). Piled the XX packing plates packed up in the waterproof.  
(將放滿產品的 XX 個 PVC 盤疊起, 裝入防水袋內)
  - (5). Seal the waterproof bag, then put the Air column bag 1PCS on the bag.  
(Put 1 PCS Air column bag at the right and left side in the paper box if it is necessary.)  
(封上防水袋, 然後放上第二塊氣柱袋)  
(必要時, 在紙箱的左右兩側各放一塊氣柱袋)
  - (6). Seal the surface of the outer box, as shown in drawing Three.  
(將外箱上層封口, 如(圖三)所示)
- The form on the right and flank side of the box must be filled correctly and clearly, take actual testing weight as the standard of each box gross weight.  
外箱之正麥和側麥所要填寫之項目要填寫正確, 清晰, 每箱之毛重應以實測重量為準.

# 歐品電子(昆山)有限公司

OUPIIN ELECTRONIC(KUNSHAN) CO.,LTD.

## PACKAGING SPECIFICATION (包裝作業規範)

CONFIDENTIAL     TOP SECRET

SPEC.NO.(規範編號)		Q9001SPP-339T1						PAGE: 4/4    REV.    Q			
PACKING MATERIAL (包裝材料)			PRODUCT P/N	CT NO.	PACKING N.W.	PACKING QUANTITY (包裝數量)			WEIGHT (重量) kg		
MATERIAL NAME (材料名稱)	PART NO. (料號)	Q'TY	(產品料號)	(紙箱規格)	(包材重量)	PCS/TRAY	TRAY/BOX	PCS/BOX	N.W./PCS	N.W./BOX	G.W./BOX
PAPER BOXES (紙箱)	CT1.6	1	9001-16481CxxA	CT-1.6	2.02	70	25	1750	0.0097	16.98	19.00
Packing Box (包裝盒)	PVC-10	----									
Packing Box Cover (包裝盒上蓋)	PVC-073-1	1									
Air column bag (氣柱袋)	-----	2									
DRYING AGENT (干燥劑)	-----	3									
WATERPROOF BAG (防水袋)	PE 100*70	1									

1.NOTE:  
 (注意)  
 H When the finished products have been made,take the actual weight as the standard of gross weight in each box.  
 (成品出貨時,每箱之毛重應以實測重量為準)  
 When the finished products have been made,stick the proper designation list on the box according to product demand.  
 CT-1.6 Produce goods taiwan , CT-1.9 Produce goods shanghai. (CT-1.6出貨台灣OP, CT-1.9出貨上海SH)  
 It doesn't influence the manner of packing with the gold-plated way to print word way.Can amalgamate.(印字方式跟鍍金方式不影響包裝方式,可以共用)